

Aqua Cooler Pty Limited

PRODUCT MANUAL

R SERIES WATER CHILLERS

001-D139

Client

Model

Serial No.

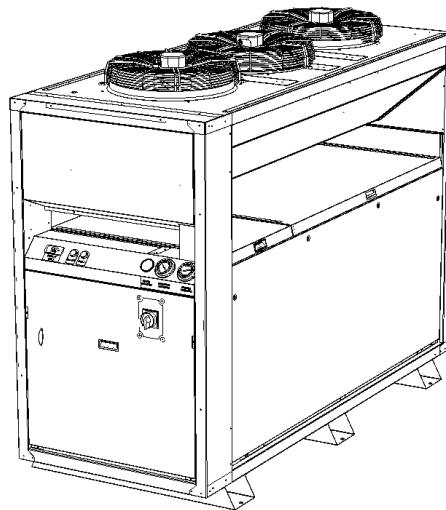

R150 R180 R230 R300 R330
R420 R540 R670 R830 R1000 R1200 R1330
R1500 R2000 R2500

Terms and Conditions of Sale

Listed below are some basic operational and installation conditions that must be adhered to for Aqua Coolers warranty to remain valid and more importantly for trouble free chiller operation. These are also the conditions under which Aqua Cooler will provide the purchaser with products

Operation

The units are sophisticated pieces of equipment and must be operated in accordance with the manner in which they are manufactured. Aqua Cooler warrants these products if they are installed, commissioned, operated and serviced in a manner consistent with the guidelines set out in this document. Aqua Cooler will not be liable for products

- Where the minimum flow rate specified in the manual is not maintained through the units at all times. This applied to units not supplied with a pump.
- Where the commissioning data is not returned to Aqua Cooler or at the very least be retained for the warranty period of the product to be accessible in the event of a fault developing with the product.
- Where the operational settings on the controller are altered without first consulting Aqua Cooler in writing
- Where the temperature cut out set point is set below 5°C without first consulting Aqua Cooler in writing
- Where the water bypass in the chiller is set to be fully closed without first consulting Aqua Cooler in writing
- Where the chiller is not installed on level surface
- Where the chiller has not been powered up for at least 4 hours before starting the chiller to allow for the sump heater to warm the compressor oil.
- Where the pressure in the sealed refrigeration system has not been checked by a refrigeration mechanic before starting the chiller to ensure that the pressure on the suction side is at least 400kPa for R407c chillers and 200 kPa for R134a chillers
- Where the chiller is installed too close to either other chillers, too close to walls or too close to a roof or awning to prevent proper ventilation of the cooling system.
- Where the information supplied to Aqua Cooler for specifying the chillers is incorrect with regards to, but is not limited to, flow rates, ambient operating condition and heat load
- Where the cooling medium used in the product causes corrosion to the product

Service

- Aqua Cooler will not warrant product where service work is not carried out by Aqua Cooler
- Aqua Cooler will only cover costs of refrigerant to the value of the specified charge indicated on the marking plate of the unit
- Aqua Cooler will pass on extra cost associated with service work carried out on chillers where neat access to facilitate servicing in a manner that is compliant with safe work practices is not provided. This also includes additional charges will apply for sites where access to the chiller is unsafe or restricted
- Aqua Cooler takes no responsibility for repairs carried out on the chiller by unauthorised service agents or if parts are installed that are not from Aqua Coolers approved supplier list

Terms and Conditions of Sale**General Conditions**

- It is not Aqua Cooler's responsibility to connect the chiller to the BMS unless agreed to before delivery of the chiller
- Costs for installations where a crane lift is required to undertake major repairs will not be covered by Aqua Cooler

Delivery and payment

- Upon the receipt of the delivery, the products should be inspected and any defects reported to Aqua Cooler promptly without delay in writing. At all times, to the extent of the relevant laws, title to the products shall remain with Aqua Cooler until Aqua Cooler has received payment in full.
- Aqua Cooler will not be liable for products that are mishandled after delivery

FOREWARD

This manual is designed to explain the installation, operation and the basic maintenance of the product. It is recommended that for service issues Aqua Cooler Pty Ltd be contacted before and work commences. A comprehensive service manual is available to be downloaded from the website.

CONTACT DETAILS

Aqua Cooler Pty Ltd
161 Orchard Road
Chester Hill NSW 2162
Australia

Toll Free 1800649233 or +612 9721 9300
Fax + 612 9721 9344

www.aquacooler.com.au

Aqua Cooler Refrigeration Trading Authorisation number is AU12165

CONTENTS

Safety	3
Marking	8
Certification	8
Warranty	9
General Information	9
Intended Use	9
Water Circuit	10
Technical Data	11
Cooling System Schematic	14
Dimensions	16
Transport and Storage	19
Installation . electrical, water connection, water treatment, control circuit and final checks	19
Operation	31
Control	31
Service and Maintenance	35
Wiring Tandem Set Up	46
Pump Curves	46
Critical Spares	47
Data Sheets	47
Trouble Shooting	49
Wiring Diagram	50
Release Notes	51
Commissioning	52
Site Inspection	55

SAFETY

THE UNIT IS DESIGNED FOR OUTDOOR USE.

**WARNING**

The unit is only to be installed, operated, maintained and serviced by qualified persons only. Operation of units such as these can be hazardous and should be serviced by persons with the proper training and qualifications.

The unit and the Product Manual has markings, warning and instructions on the safe operation of the unit and they should be adhered to.

- This unit is designed to be safe in the use for which it was planned provided that it is installed, started up and maintained in accordance with the instructions contained in this manual.
- The unit contains electrical components that operate at line voltage and contains moving parts. It therefore must be isolated from the electrical supply before being worked on. All maintenance operations that require access to the unit must be carried out by suitably qualified technicians who have a thorough understanding of all necessary precautions associated with refrigeration and electrical machinery.
- The liquids to be cooled must be compatible with the materials used in the constructions of this unit. These liquids can be water or mixtures of glycol and water for example. The liquids to be cooled must not be flammable.
- All panels must be re-installed after carrying out any maintenance work.
- The unit is not to be used by the infirmed or children unless they are supervised by responsible persons qualified to carry out the supervision.
- The unit should be secured to prevent it from toppling over.
- Always isolate power from the unit when working on it.
- Minimum temperature setting is 5 degrees on the unit. Any lower than this may cause problems with the evaporator icing up and potentially loss of refrigerant and potentially expensive service costs

**WARNING**

All wiring must be performed by qualified electricians. Improperly installed wiring and grounding may result in electrocution and fire hazards

To avoid these hazards all wiring must be installed in accordance with all the local relevant safety standards for wiring

**WARNING**

The chiller contains refrigerants under high pressure. The system also contains oils under high pressure. Before the refrigeration circuit can be opened, the refrigerant should be reclaimed to reduce pressure in the system.

Failure to recover the refrigerant to relieve pressure or the use of refrigerants or refrigerant substitutes that are not specified for the unit may result in system rupture and explosion.

Refrigerants have a narcotic effect when inhaled in high quantities. Should a leak occur of the refrigerants then the room should be vacated and should only be re-entered after suitable ventilation.

SAFETY

The R150 to R330 unit have R134a refrigerant . the R420 to the R2500 has R407c refrigerant. They have different refrigeration properties but both are similar properties from a hazardous materials perspective.

R407c**First Aid**

- Eye Contact. Immediately flush with tepid water or sterile saline solution. Hold eyelids apart for 15 minutes while irrigating. Seek medical attention.
- Inhalation. Remove from area of exposure immediately and if you are assisting a victim avoid being exposed. Breathing apparatus must be worn in the presence of high concentration of refrigerants. If victim is not breathing then apply artificial respiration and seek urgent medical help. Give oxygen is available.
- Skin Contact. Cold Burns. Remove contaminated clothing and gently flush affected area with warm water (30C) for 15 minutes. Apply sterile dressing and treat as for a thermal burn. For large burns immerse in water for 15 minutes. DO NOT apply any form if direct heat. Seek medical attention.
- Ingestion. For advice contact the poisons centre on 131126 in Australia. If swallowed do not induce vomiting. Ingestion is considered unlikely due to product form.
- Advice to Doctor. Use of adrenaline and other catacholamines may be contraindicated due to possible cardiac sensation. Treatment for asphyxia.

R407 HazChem code 2RE

R407 is non . flammable.

R134a HazChem code 2RE

R134a is non . flammable.

2. COMPOSITION / INFORMATION ON INGREDIENTS

<u>INGREDIENT NAME</u>	<u>CAS NUMBER</u>	<u>WEIGHT %</u>
1,1,1,2-Tetrafluoroethane	811-97-2	100

Trace impurities and additional material names not listed above may also appear in Section 15 toward the end of the MSDS. These materials may be listed for local "Right-To-Know" compliance and for other reasons.

3. HAZARDS IDENTIFICATION

EMERGENCY OVERVIEW: Colorless, volatile liquid with ethereal and faint sweetish odor. **Non-flammable material.** Overexposure may cause dizziness and loss of concentration. At higher levels, CNS depression and cardiac arrhythmia may result from exposure. Vapors displace air and can cause asphyxiation in confined spaces. At higher temperatures, (>250°C), decomposition products may include Hydrofluoric Acid (HF) and carbonyl halides.

POTENTIAL HEALTH HAZARDS

SKIN: Irritation would result from a defatting action on tissue. Liquid contact could cause frostbite.

EYES: Liquid contact can cause severe irritation and frostbite. Mist may irritate.

INHALATION: R-134A is low in acute toxicity in animals. When oxygen levels in air are reduced to 12-14% by displacement, symptoms of asphyxiation, loss of coordination, increased pulse rate and deeper respiration will occur. At high levels, cardiac arrhythmia may occur.

INGESTION: Ingestion is unlikely because of the low boiling point of the material. Should it occur, discomfort in the gastrointestinal tract from rapid evaporation of the material and consequent evolution of gas would result. Some effects of inhalation and skin exposure would be expected.

DELAYED EFFECTS: None Known

SAFETY

ACCIDENTAL RELEASE MEASURES

IN CASE OF SPILL OR OTHER RELEASE: (Always wear recommended personal protective equipment.)
Evacuate unprotected personnel. Protected personnel should remove ignition sources and shut off leak, if without risk, and provide ventilation. Unprotected personnel should not return until air has been tested and determined safe, including low-lying areas.

4. FIRST AID MEASURES

SKIN: Promptly flush skin with water until all chemical is removed. If there is evidence of frostbite, bathe (do not rub) with lukewarm (not hot) water. If water is not available, cover with a clean, soft cloth or similar covering. Get medical attention if symptoms persist.

EYES: Immediately flush eyes with large amounts of water for at least 15 minutes (in case of frostbite, water should be lukewarm, not hot) lifting eyelids occasionally to facilitate irrigation. Get medical attention if symptoms persist.

INHALATION: Immediately remove to fresh air. If breathing has stopped, give artificial respiration. Use oxygen as required, provided a qualified operator is available. Get medical attention immediately. **DO NOT** give epinephrine (adrenaline).

INGESTION: Ingestion is unlikely because of the physical properties and is not expected to be hazardous. **DO NOT** induce vomiting unless instructed to do so by a physician.

ADVICE TO PHYSICIAN: Because of the possible disturbances of cardiac rhythm, catecholamine drugs, such as epinephrine, should be used with special caution and only in situations of emergency life support. Treatment of overexposure should be directed at the control of symptoms and the clinical conditions.

5. FIRE FIGHTING MEASURES**FLAMMABLE PROPERTIES**

FLASH POINT:	Gas, not applicable per DOT regulations
FLASH POINT METHOD:	Not applicable
AUTOIGNITION TEMPERATURE:	>750°C
UPPER FLAME LIMIT (volume % in air):	None*
LOWER FLAME LIMIT (volume % in air):	None*
	*Based on ASHRAE Standard 34 with match ignition
FLAME PROPAGATION RATE (solids):	Not applicable
OSHA FLAMMABILITY CLASS:	Not applicable

EXTINGUISHING MEDIA:

Use any standard agent – choose the one most appropriate for type of surrounding fire (material itself is not flammable)

UNUSUAL FIRE AND EXPLOSION HAZARDS:

R-134A is not flammable at ambient temperatures and atmospheric pressure. However, this material will become combustible when mixed with air under pressure and exposed to strong ignition sources. Contact with certain reactive metals may result in formation of explosive or exothermic reactions under specific conditions (e.g. very high temperatures and/or appropriate pressures).

A full material safety data sheet for R134a refrigerant gas is available at

<http://www.refrigerants.com/msds/r134a.pdf>

Disposal

The unit must be disposed of in a proper fashion. The refrigerants in the system must be reclaimed by a qualified refrigeration mechanic and disposed of in accordance with the statutory requirements. The compressor contains oil that must not be dumped.

Manual Handling

The chillers are very heavy; do not try to move the units manually. The unit can be lifted with a crane (the centre of gravity is towards the front of the unit), a forklift or a pallet jack.

MARKING

The units have various markings on them. There is a marking plate on the unit, an example is shown below giving regulatory requirements. There will be a wiring diagram as shown in the wiring diagram section of this document provided in a larger scale for ease of maintenance.

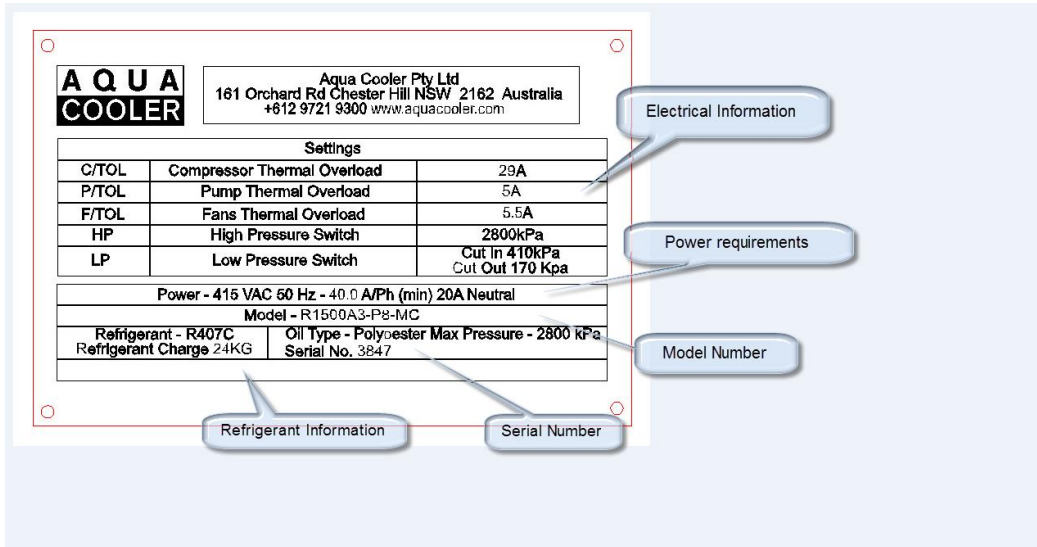

A four digit serial number sticker will also be placed under the marking plate. With this number Aqua Cooler can trace the date of manufacture of the product and details on the unit. The wiring diagram will show the model of the unit and the options installed. The designation below outlined the available options

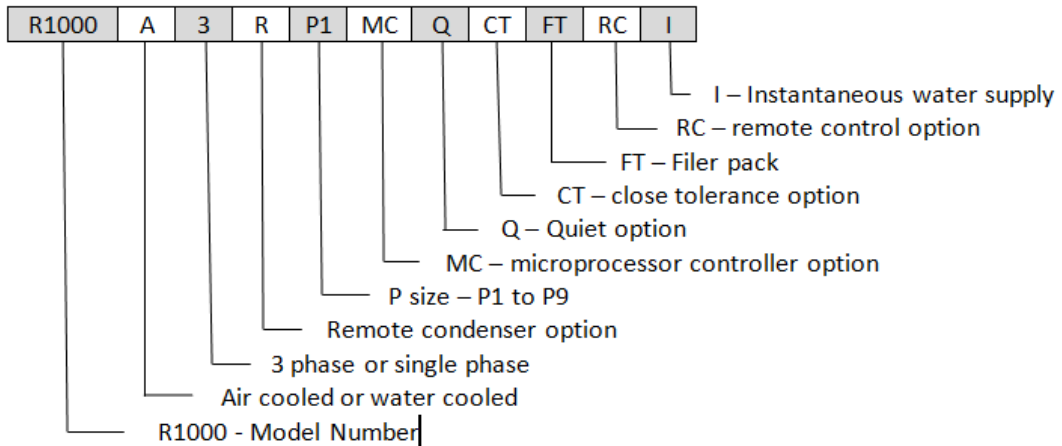

CERTIFICATION

All the electrical components in the chiller have certification for electrical safety. The electrical box and all the exposed components are rated to IP66 against weather ingress.

WARRANTY

Any claim under this warranty must be made within 12 months of the date of purchase of the product. To make a claim under the warranty, return the product (with proof of purchase) to the supplier where you purchased the product or contact Aqua Cooler regarding warranty conditions.

Aqua Cooler will pay your reasonable, direct expenses of claiming under this warranty. You may submit details and proof of your expense claim to Aqua Cooler Pty Ltd for consideration.

This warranty is given by Aqua Cooler Pty Ltd, ABN 13 245 994 351, of 161 Orchard Rd, Chester Hill, NSW 2162 . ph 02 9721 9310.

This warranty is provided in addition to other rights and remedies you have under law: Our goods come with guarantees which cannot be excluded under the Australian Consumer Law. You are entitled to replacement or refund for a major failure and to compensation for other reasonably foreseeable loss or damage. You are also entitled to have the goods repaired or replaced if the goods fail to be of acceptable quality and the failure does not amount to a major failure.

Attached to this document is a comprehensive commissioning procedure. This must be carried out in accordance with the procedure and returned to Aqua Cooler or Aqua Cooler can do the commissioning, otherwise the warranty will be voided.

GENERAL INFORMATION

The chiller is designed to refrigerate and circulate water to a heat developing process to aid in keeping that process cool. They are supplied with an immersed coiled copper evaporator or plate heat exchanger, an air cooled condenser and a scroll compressor to circulate the refrigerant gas. Water is circulated out of the unit via a pump. The controller is available in two options - either the Aqua Cooler proprietary microprocessor with high level control and high level interface or a basic controller controlling the chillers basic functions. This must be specified at the time of order.

INTENDED USE

The chiller is design to be installed outdoors and refrigerate water for a heat developing process . not for drinking or food preparation purposes. Any other use of this water chiller is a not as it is intended.

CHILLED WATER CIRCUIT

The chiller can be installed to feed a remote buffer tank or be a closed loop system. Whichever installation id required MUST be specified at the time of order.

The chilled water circuit consists of

1. Plate heat exchanger or copper evaporator
2. Flow meter - optional
3. One way valve . optional
4. Pump
5. Motorised Ball Valve . optional
6. Expansion tank . for closed loop systems
7. Pressure relief valve . feeds to drain in closed loop system
8. Filter pack . if ordered . 0.5 micron

The chilled water path starts with the pump delivering the water through a one way valve and to the process. The return water passes through a flow meter to monitor the flow rate, through the evaporator and back to the pump.

The primary pump will run full time unless the system detects a drop in flow.

It is important to ensure that any water treatment is passive to the wetted parts of the system which include

- Stainless Steel
- Copper
- High Density Polyethylene
- Brass
- ABS Plastic
- Nitrile Rubber

TECHNICAL DATA

All power data, current draw and power consumption of the compressor and the chiller is based on the prescribed refrigerant for each unit. For the R420 to the R2500 if R134a is used then reduce power consumption by approximately 30%. The power consumption of the unit will also change for units supplied with R404 or R410a. Contact Aqua Cooler for accurate data on non-standard chillers

R SERIES I – R150 to R330

PERFORMANCE DATA						
Model		R150	R180	R230	R300	R330
Compressor horsepower	hp	1.5	1.8	2.3	3.0	3.3
Cooling capacity						
5°C supply						
Power input – 45 Ambient	kW	1.6	1.8	2.5	3.0	3.6
Power input – 35 ambient		1.1	1.5	2.0	2.4	3.0
COP – 45 Ambient		1.4	1.6	1.5	1.5	1.4
COP – 35 Ambient		2.0	1.9	1.9	1.9	1.7
Current draw – 45 ambient	Amps	2.7	3.4	4.8	5.7	7.0
Current draw – 35 Ambient		2.2	2.8	3.6	4.7	5.7
10°C supply						
Power input – 45 Ambient	kW	1.6	1.8	2.5	3.0	3.7
Power input – 35 ambient		1.1	1.5	2.1	2.4	3.0
COP – 45 Ambient		1.6	1.8	1.8	1.8	1.7
COP – 35 Ambient		2.3	2.2	2.1	2.3	2.1
Current draw – 45 ambient	Amps	2.7	3.5	4.9	5.8	7.1
Current draw – 35 Ambient		2.2	2.8	3.6	4.7	5.8
15°C Supply						
Power input – 45 Ambient	kW	1.6	1.8	2.6	3.0	3.7
Power input – 35 ambient		1.2	1.5	2.1	2.5	3.0
COP – 45 Ambient		1.9	2.3	2.1	2.2	2.1
COP – 35 Ambient		2.6	2.8	2.6	2.6	2.7
Current draw – 45 ambient	Amps	2.8	3.5	5.0	5.9	7.2
Current draw – 35 Ambient		2.3	2.9	3.6	4.8	5.8
20°C Supply						
Power input – 45 Ambient	kW	1.6	1.8	2.6	3.1	3.7
Power input – 35 ambient		1.2	1.5	2.1	2.5	3.0
COP – 45 Ambient		2.4	2.8	2.6	2.6	2.6
COP – 35 Ambient		3.3	3.4	3.2	3.2	3.2
Current draw – 45 ambient	Amps	2.8	3.6	5.0	6.0	7.2
Current draw – 35 Ambient		2.3	2.9	3.7	4.8	5.9
Power input figures and current draw include the fan but not the pump if supplied						

TECHNICAL DATA

ELECTRICAL DATA		R150	R180	R230	R300	R330
Power requirements – single phase		240V 50 Hz Single Phase			Not readily available in single phase	
Maximum current draw – single phase ²	A/ Ph	15	17.1	22.1		
Maximum current draw – 3 phase	A/ Ph	9.0	9.8	10.9	11.8	13.1
Maximum continuous current – compressor	A/ Ph	7.0	9.5	10	13	15
Locked rotor amps – compressor	A/ Ph	30	45	45	60	70
Rated load amps	A/ Ph	4.5	6.1	6.4	8.3	9.6
Power requirements – 3 phase – 380/ 415V 50 Hz 3 phase plus neutral (4A Max)						

PUMP CURVES – the chillers are available with 3 pump flow/ pressure options

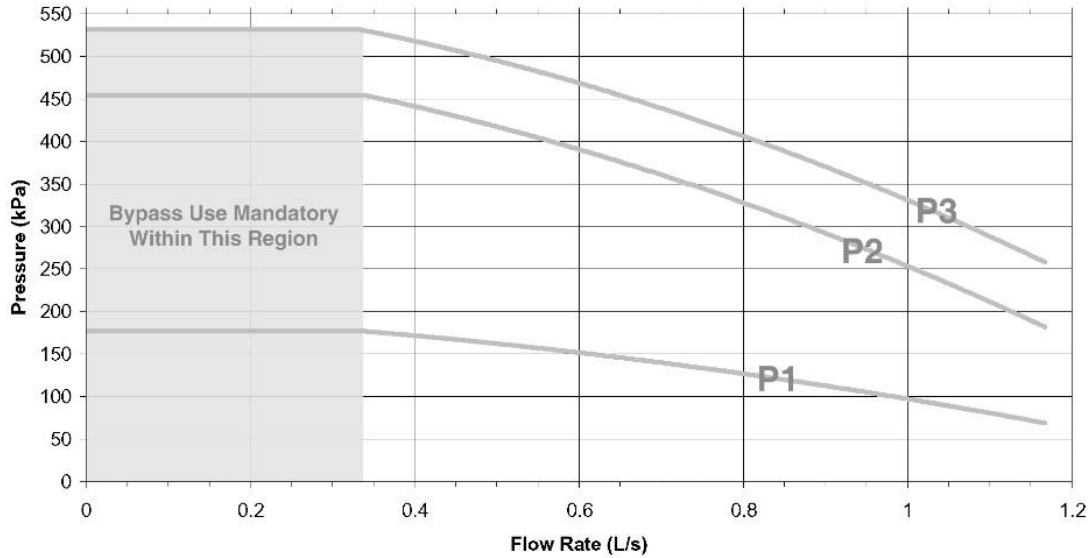

TECHNICAL DATA

R420 to R1330

PERFORMANCE DATA – R134a

Model		R420	R540	R670	R830	R1000	R1200	R1330
Compressor horsepower	hp	4.2	5.4	6.7	8.3	10	12	13
Cooling capacity								
0° supply	kW	5.8	7.7	9.6	11.1	14.8	16.8	18.1
Power input – 45 Ambient	kW	4.1	4.8	5.6	6.9	7.5	8.8	10.6
Power input – 35 Ambient	kW	3.4	4.8	5.6	6.2	7.1	8.0	9.5
Current draw – 45 Ambient	Amps	7.0	11.6	13.0	14.9	20.0	23.2	24.9
Current draw – 35 Ambient	Amps	5.4	9.0	10.9	12.6	16.7	19.3	20.7
COP 45 Ambient		1.4	1.5	1.6	1.6	2.0	1.9	1.7
COP 35 Ambient		1.7	1.6	1.7	1.8	2.2	2.1	1.9
5° supply	kW	6.1	8.1	10.3	11.7	15.6	17.5	19.2
Power input – 45 Ambient	kW	3.8	6.4	7.6	8.7	8.7	8.8	10.1
Power input – 35 Ambient	kW	3.4	4.8	5.7	6.2	6.6	8.0	9.1
Current draw – 45 Ambient	Amps	7.1	11.7	13.0	14.9	20.0	23.2	25.0
Current draw – 35 Ambient	Amps	7.0	10.9	12.0	12.5	16.7	19.3	20.7
COP 45 Ambient		1.6	1.7	1.8	1.8	2.2	2.1	1.9
COP 35 Ambient		1.8	1.9	2.0	2.1	2.5	2.5	2.4
10° supply	kW	7.5	9.7	12.5	14.2	18.8	21.2	24.4
Power input – 45 Ambient	kW	3.8	6.4	7.6	8.7	8.7	8.8	10.1
Power input – 35 Ambient	kW	3.5	4.9	5.8	6.2	6.7	8.1	9.2
Current draw – 45 Ambient	Amps	7.2	11.7	13.1	14.9	20.3	23.4	25.6
Current draw – 35 Ambient	Amps	7.0	11.0	12.1	12.6	16.8	19.4	20.8
Current draw		3.9	6.6	7.7	10.8	14.1	16.7	16.9
COP 45 Ambient		1.8	1.9	2.0	2.1	2.4	2.3	2.1
COP 35 Ambient		2.1	2.0	2.2	2.3	2.6	2.6	2.4

ELECTRICAL DATA

Model		R420	R540	R670	R830	R1000	R1200	R1330
Maximum continuous current – compressor	A/ Ph	12.5	15.0	17.0	17.0	19.0	29.0	32.0
Locked rotor amps – compressor	A/ Ph	62	87	87.0	86	98	130	145
Rated load amps	A/ Ph	8	9.6	11.0	12.1	13.6	20.7	22.9
Power requirements – 3 phase – 380/ 415V 50 Hz 3 phase plus neutral (4A Max)								

PUMP CURVES – Standard Offerings

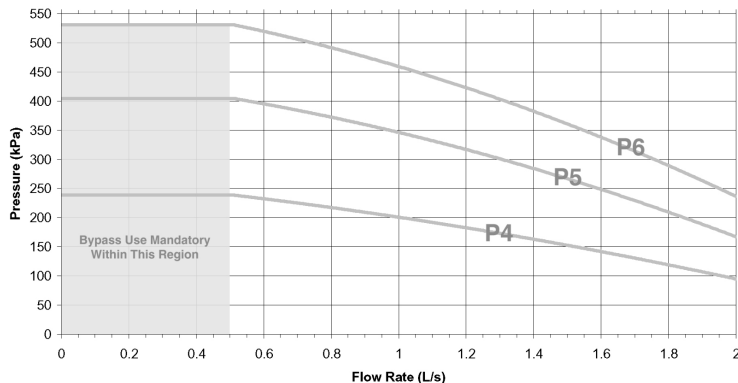

TECHNICAL DATA

R SERIES III – R1500 TO R2500

PERFORMANCE DATA – R407c Refrigerant

	R1500	R2000	R2500
Cooling Capacity			
5° supply	30.8	36.5	49.5
Power input – 45 ambient	15.4	22.9	27.6
Power input – 35 Ambient	13.7	18.4	22.5
COP – 45 Ambient	2.0	1.6	1.8
COP – 35 Ambient	2.2	2.0	2.2
Current draw – 45 Ambient	26.5	37.2	45.2
Current draw – 35 Ambient	24.3	31.1	38.0
10° supply	36.5	46.0	61.0
Power input – 45 Ambient	15.4	23.2	28.1
Power input – 35 Ambient	13.7	18.7	22.9
COP – 45 Ambient	2.4	2.0	2.2
COP – 35 Ambient	2.7	2.5	2.7
Current draw – 45 Ambient	26.6	37.6	45.8
Current draw – 35 Ambient	24.3	31.4	38.5
15° supply	41.0	55.5	68.5
Power input – 45 Ambient	15.5	23.5	28.6
Power input – 35 Ambient	13.8	18.9	23.3
COP – 45 Ambient	2.6	2.4	2.4
COP – 35 Ambient	3.0	2.9	2.9
Current draw – 45 Ambient	26.7	38.1	46.2
Current draw – 35 Ambient	24.4	31.7	39.0
Current draw numbers do not include the current draw of the chilled water supply pump			

PUMP CURVES – STANDARD OFFERING

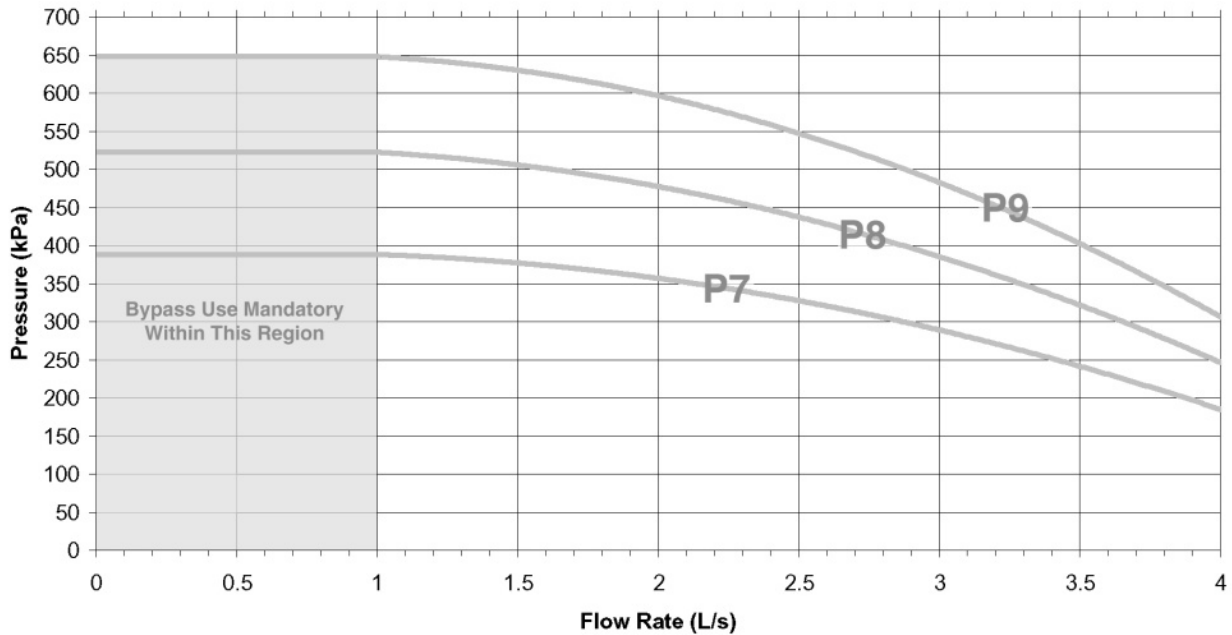

TECHNICAL DATA

GENERAL DATA – R1500 to R2500

Model	All Models				
High pressure safety cutout pressure – R134a	kPa	2300	Low pressure safety cut out pressure – R134a	kPa	80 – reset at 170
High pressure safety cut out pressure – R407c	kPa	2850	Low pressure safety cut out – R407c	kPa	170 – reset at 400
Noise rating at 5m – dB	dB	73	No. of fans		3
Fan speed control	Variable/ Automatic		Hot air discharge	Vertical	
Fan type	Axial 4 pole 3 phase		Capacity control	0-100%	
Maximum air flow	16700m³/ hr		Fan wiring	Y Star – 3 Phase	
Overflow connection	2" FBSP		Chilled Water connection	1 ½" FBSP	
Make up water connection	3/8" FBSP		Drain connection	2" FBSP	
Buffer tank capacity	500L		Buffer tank construction	HDPE with polyurethane foam insulation	
No. of compressors	1		Compressor type	Scroll – hermetic	
Compressor oil	POE		Liquid receiver volume	10.6 L	
Refrigerant type	R407c – option for R134a		TX/ expansion valve type	Mechanical expansion	
Compressor start method	DOL		Compressor motor insulation	Class F	
Controller	Standard unit – off the shelf – 0.1C accuracy Microprocessor controller – Aqua Cooler				
High level BMS connection protocols	Bacnet, SNMP and Modbus as standard LON works as an option All BMS stacks are imbedded without the need for a gateway				
Condenser construction	Expanded 7mm rifle bore copper tube with 0.12mm aluminum fins				
Condenser coating	Hydrophobic epoxy coating				
General unit construction	Electrostatic powder coated galvanized steel				
Centre of gravity	Unit is 45/55 along the long axis of the machine Unit is weighted 60/40 about the short centre line				
Model	R1500	R2000	R2500		
Approximate shipping weight	800 kg	900 kg	950 kg		
Oil charge	6.2 kg	8.0 kg	8.0 kg		
Refrigerant charge	9 kg	10 kg	10 kg		
Minimum water flow across the evaporator	1.8 l/s	2.3 l/s	3.0 l/s		
Evaporator					
Evaporator type	Plate heat exchanger		Cooling medium	Water	
Pressure drop across evaporator at minimum flow rate	kPa	50	Maximum design operating pressure water side	kPa	1000
Minimum flow rate through evaporator	l/s	83	Fouling factor – evaporator	m ³ C/kW	0.006
Evaporator options include					
<ul style="list-style-type: none"> ○ Immersed coil for dirty environment/ low flow/ low water temperature applications ○ Stainless shell and tube for corrosive environments 					

COOLING SYSTEM SCHEMATIC

Immersed Copper Coil Evaporator

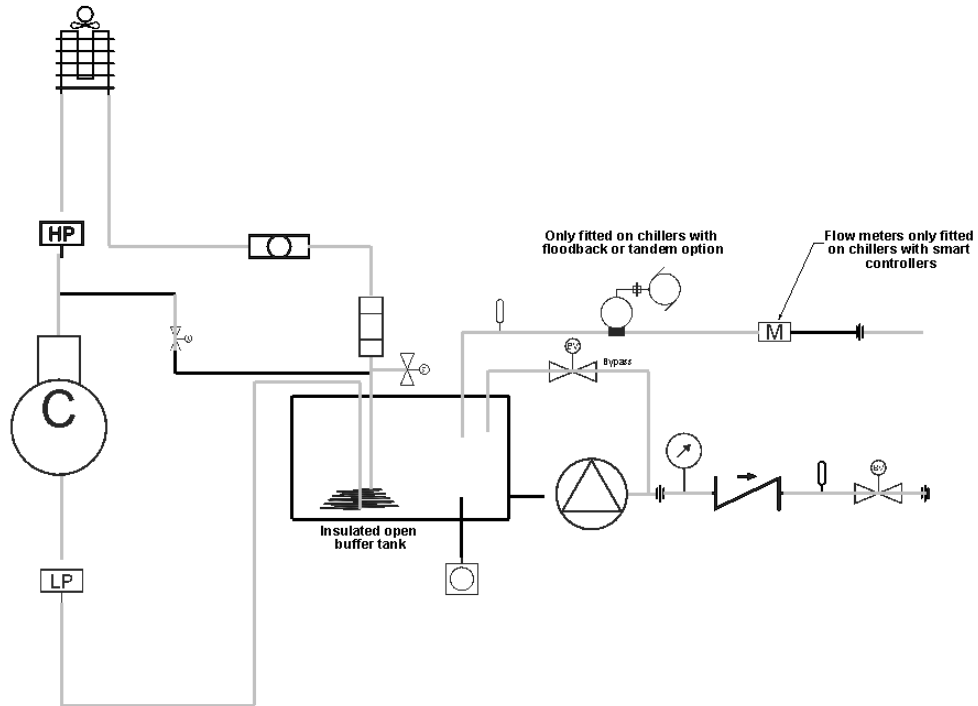

Brazed Plate Heat Exchanger Evaporator Model

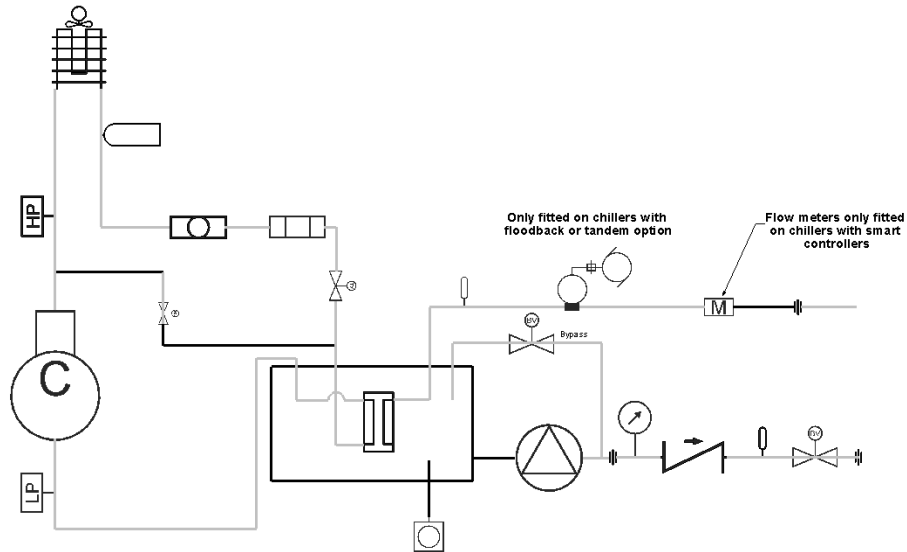

COOLING SCHEMATIC

Closed Loop Installation

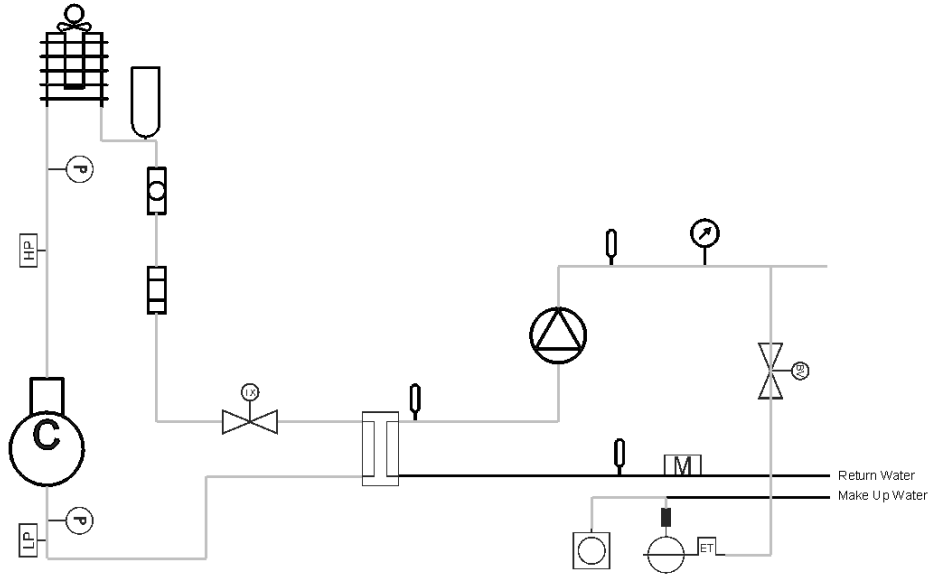

Cooling Schematic Symbols

	Liquid receiver		Air Cooled Condenser		Pressure transducer
	Pump		One way valve		Ball valve
	Compressor		TX valve		Flow meter
	Sight glass		Drier		Pressure gauge
	Low pressure switch		Drain		Thermowell
	Motorised ball valve		Expansion tank		Water regulating valve
	Pressure relief valve		Strainer		High pressure switch
	Hot gas bypass valve		Isolation valve		Plate heat exchanger

DIMENSIONS

Standard Chillers
R150 to R330

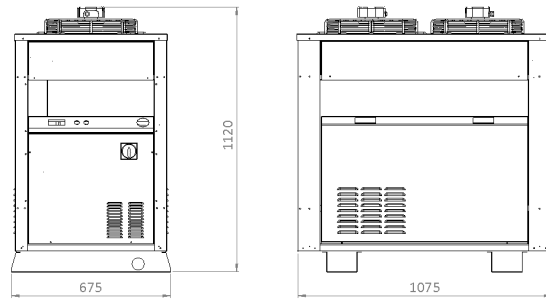

R420 to R1330

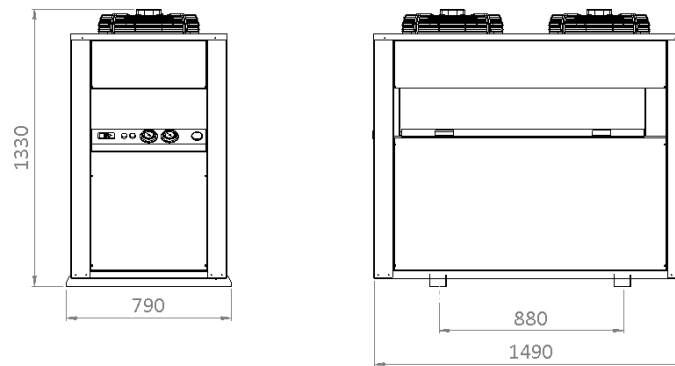

R1500 to R2500

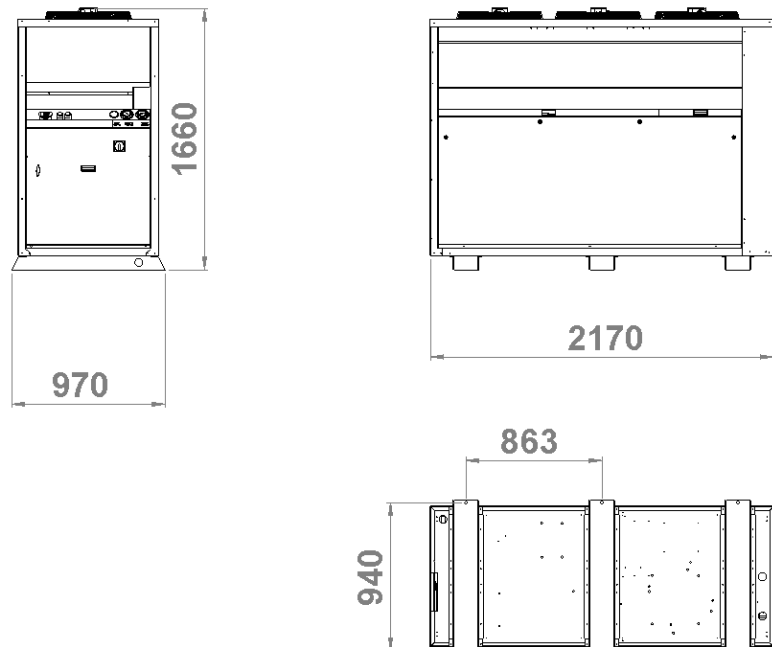

DIMENSIONS

R420 to R1330 Remote Unit

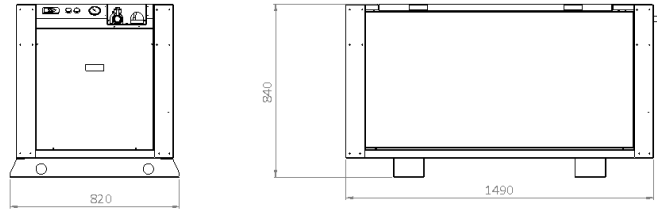

COOLING UNIT

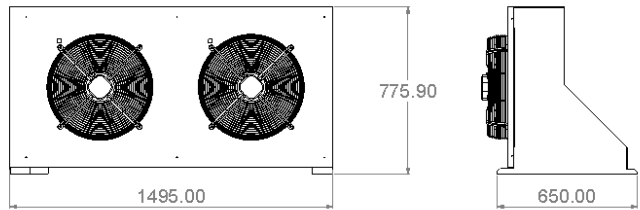

CONDENSING UNIT

R1500 to R2500 Remote Unit

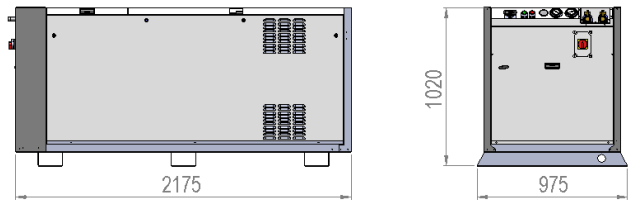

Compact Chiller – no buffer tank – Model RTDPC25 – 25 to 50kW

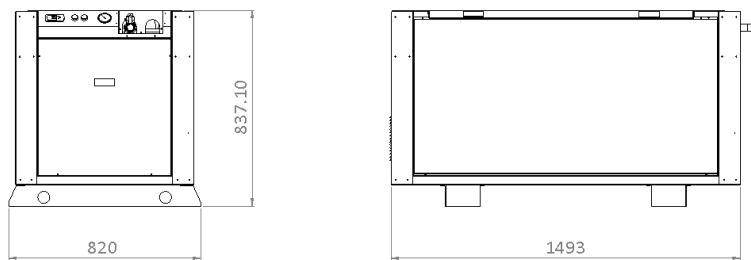

DIMENSIONS

R1500 Remote Condenser

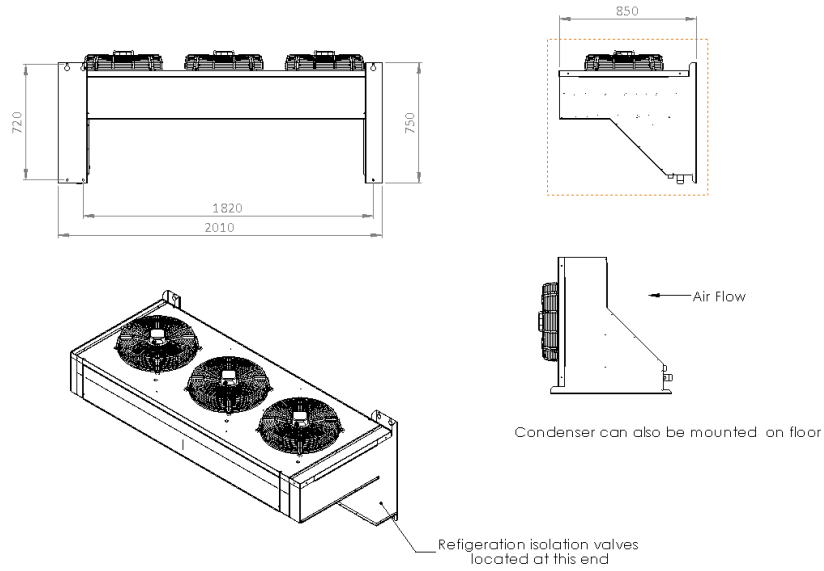

R2000/ R2500 Condenser

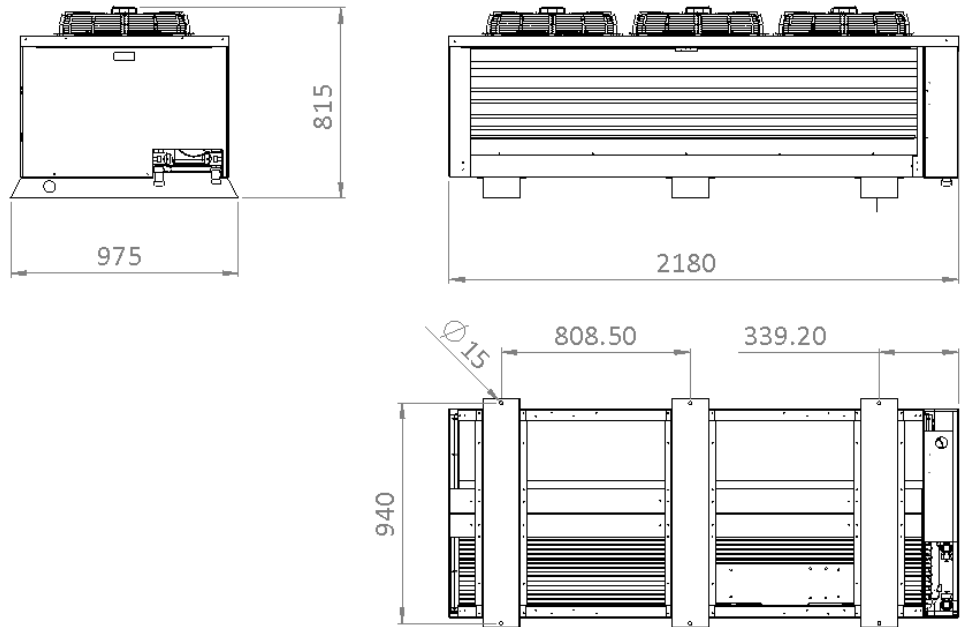

TRANSPORT AND STORAGE

Immediately upon receipt of the chiller, carefully inspect the chiller for any damage that may have occurred in transit. Any such damage must be noted on the carrier's delivery documents. It is the consignee's responsibility to make any subsequent claims upon the carrier or respective insurance company.

Any hidden damage should be reported to Aqua Cooler as soon as possible.

If the unit is to be stored before installation then care must be taken to ensure no foreign matter can get into the water pipes. If the storage is for a prolonged period it is recommended that the water circuit be changed with nitrogen and sealed.

The unit has been designed to be lifted with a forklift or a crane. The standard unit is heavier towards the front looking at the chiller side on and care must be taken when lifting with a crane that the strapping does not damage the side panels. The remote condenser unit can be lifted along its centre line in both directions. The units are also designed to be moved around with a pallet jack.

INSTALLATION

A comprehensive commissioning program carried out by qualified refrigeration mechanics is available through Aqua Cooler. Benefits of this service include extended warranty. For full details and conditions please contact Aqua Cooler. There is also a site inspection procedure at the end of this manual. It is strongly recommended that Aqua Cooler or one of its agents carry out a site inspection to confirm that the installation site will not compromise the chillers performance.

The water fittings on the standard unit are at the rear of the unit . that is the end as the unit away from the electrical box and the unit should be positioned so this end is as close to the process as possible. The remote condenser unit has the water fittings marked on the front of the module.

At least 800mm should be left around the unit to allow for proper ventilation of the condensers . see diagram. The unit should not be installed in a closed off room and if it is to be installed under anything then there should be a minimum of 2 metres of clear air above the unit.

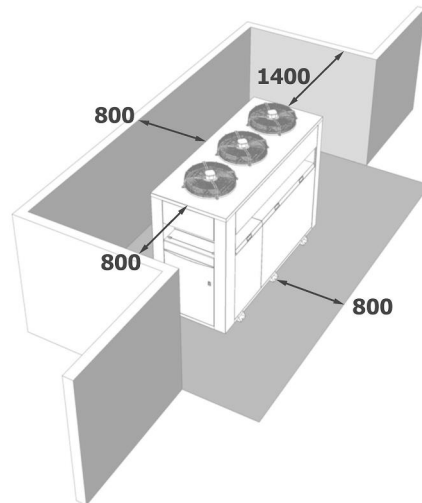

INSTALLATION

The commissioning section at the end of this manual has a site inspection check list designed to aid in checking that the site for the chiller installation is suitable. This should be filled out by someone experienced in chiller installation and returned to Aqua Cooler if there are any doubts about the installation. It is essential to ensure that adequate and safe service access to the chiller is provided. Failure to provide safe access to the chiller may lead to additional charges should servicing be required.

When installing indoors it is important to understand that the chiller will impart a significant heat load into the environment and it is essential to ensure a plentiful, unrestricted supply of ambient temperature air to the chiller. Should you have concerns over the installation site then please contact Aqua Cooler for advice.

Note: Under no circumstances is ducting to be attached to the condenser fan outlet.

This chiller has been designed to draw air from each side and to exhaust vertically through the top of the unit. Preferably there should be no obstructions above the chiller, with a minimum of one metre clearance permitted in other circumstances. In addition to ensuring sufficient space around the chiller for free air movement, provision must be made around the chiller for service and regular maintenance. The chiller must be installed on a firm and level foundation, of adequate strength to support the chiller's full operating weight.

Installation of the Water Path

Before connecting the make-up water, check the suction pressure on in the chiller is above 400kPa OR 200 kPa for chillers with R134a refrigerant. A refrigeration mechanic can do this with gauges or if the unit has a smart controller the pressure can be viewed on the display on the controller in the electrical box.

By removing the lower front panel a set of access point can be seen next to the electrical box. They will be marked by the high side (discharge) is the higher of the two points and the low side (suction) is the lower of the two.

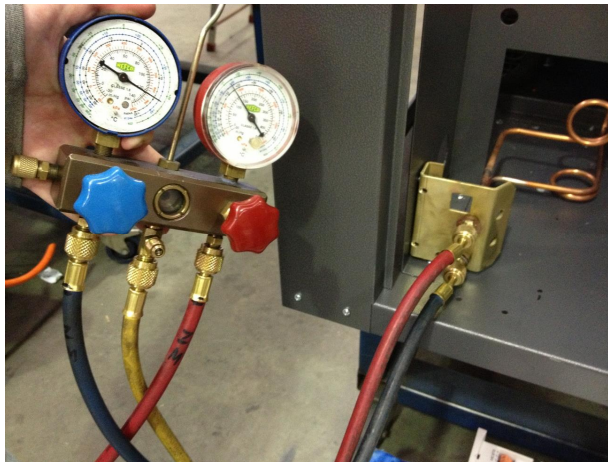

If the pressure is below this then there may be a leak in the refrigeration circuit and water may be drawn into the refrigeration circuit on start up. If the pressure is below this then it is recommended that the chiller be inspected by a qualified refrigeration mechanic before filling the system with water.

INSTALLATION

On the rear of the standard and the remote unit with the buffer tank and on the front of the refrigeration module of the remote condenser version, the supply and return connections will be marked next to the water fittings. The water fittings are 1 ½" female BSP. The supply water is to the chilled water to the process and the return water is the water from the process with the heat load. The make-up water is also mounted on this bracket and is designed to be used with ½" female BSP. If the make-up water pressure is greater than 700kPa then a pressure limiting valve must be fitted.

All pipe work with refrigerated water running to and from the chiller should be fitted with a water resistant insulation material to prevent sweating and maximise the efficiency of the chiller.

Electrical Installation

The chiller draws a large amount of current and it is important that the connection of the unit to the power supply must be carried out in accordance with the local standards and only by a licensed electrician.

The power supply system on site and the circuit protection must be designed for the total current of the unit taking into account the inrush current and the lock rotor amps of the compressor. see Technical Data. The circuit breaker must be set no more than 125% of the units rated load current.

The power supply system on site and the fuses must be designed for the total current of the unit. see technical data.

Mains supply cables must be sized to ensure adequate voltage at the chiller under all load conditions. Three phase power must be symmetrical, ensuring equal effective voltage and equal phase angle between consecutive phases. The pump and the compressor rely on correct phase rotation.

The chiller has an isolation switch mounted on the mounted behind the lower front panel. The power supply cable can be fed through the marked access hole at the rear of the chiller or through the marked access hole in the base of the chiller under the electrical box and into the isolation switch through the gland provided. Ensure the phases are match with the cables installed. The holes in the chillers feet are designed to aid in cable management.

After installation the electrical box should be shut properly and the cover of the isolation switch re-attached properly to ensure their water ingress ratings are maintained. Ensure that the cable is free of hot spots and sharp edges.

Ensure all electrical connections are tight prior to start up.

Power should be provided to the unit for as long as possible. minimum of three hours. before start up to ensure that the sump heater will boil off refrigerant from the sump oil. The unit is now ready to be started up.

Remote Monitoring and Control Panel – only available with MC models only

The chiller can be supplied with a remote panel designed to be mounted in the area near the process to monitor the operation of the chiller. There are two styles. a higher level display with a LCD screen to show chiller function or a low level display with a run and a fault light only. Some details on these displays will help with chiller identification should it be required in the event of a fault such as serial number and chiller model.

INSTALLATION

For both models of display there is a 24VDC master run light (green) and a fault light (red). Both will need to be wired back to the electrical box using 2 wires for each light. The terminals for the fault light are 10/11 and the terminals for the master run light are 12/13 . both will be marked on the wiring diagram.

Both can also be installed with an ON/OFF switch and the wiring diagram will show the wiring location for this as well. This must be specified at time of order.

Installing the Display Panel with LCD System Status Readout – only available with smart controller

A CAT5 cable will need to be run from the chiller to the room with the process. The remote display comes in two halves and the rear plate will need to be mounted to the wall via the 4 mounting holes shown on the diagram.

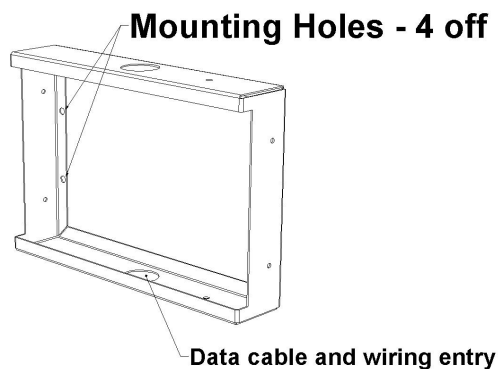

Once this secure then feed the CAT5 cable from the chiller and clip it into the underside of the display as shown in the diagram . there is a cut out in the bottom of the plastic moulding. Once the CAT5 cable and the low voltage wiring is installed press the front part of the assembly over the plate mounted to the wall and screw into place with the self tapping screws provided.

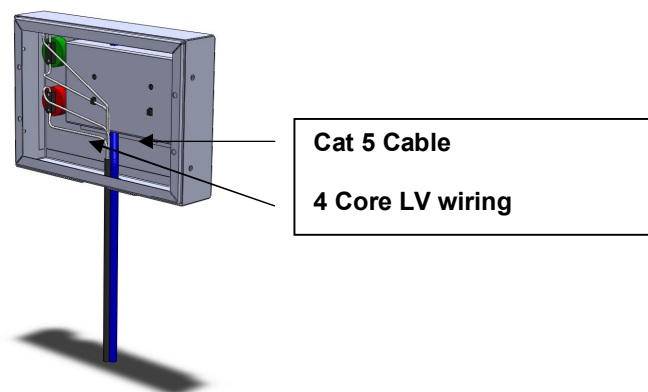

The LCD display will give the water temperature, flow rates, faults and the performance parameters of the chiller.

INSTALLATION

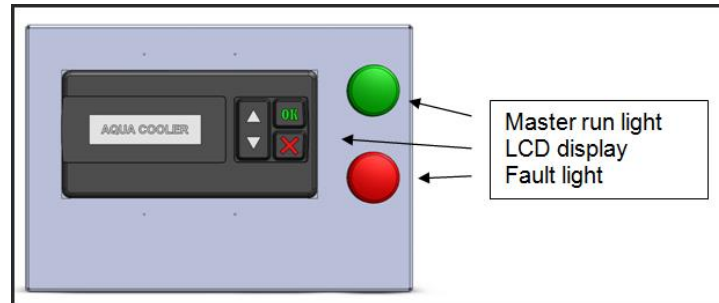

Noting what these faults are will aid in diagnosing problems when speaking to the service department.

Installing the Display Panel with Basic System Status

Again the display comes in two halves. There is a body that will need to be mounted to a wall and then the facia with the light is pressed onto the base. A blanking plug is also supplied should the stop/switch be unnecessary.

**Customising the High Level – Web Based – Interface – only available with smart (MC Models) controller**

The chiller has programming to allow it to be connected to the internet for monitoring or to be monitored via high level SNMP interface. Aqua Cooler can install customer IP address prior to the unit being dispatched other wise see the service section of this document for instructions on changing the system settings. The system can also communicate via BACNet and Modbus protocols but they must be specified at the time of order.

INSTALLATION

To connect the chiller to your network or use a laptop on site

- Connect a CAT5 cable to the Ethernet port on the circuit board
- Open a browser and enter <http://10.1.1.130:8076>
- Go to the %Status+page and log in using %echcooler+ as user name and %echwater+ as the password. This means you are now logged in as Administrator. The webpage should appear showing the status of the chiller
- To change the chillers IP address go to the %Advanced+tab on the home page and then %Network+tab on the left hand side. Put %aquaipconfig+ into the password page and un-tick the %DHCP+enable tab. This will allow the loading of the site specific IP address.
- To load in email addresses go to the %Email+tab on the left hand side and use the password %aquaemail+ The chiller will now send an email on fault. If at any time you wish to have a data log file sent go to the %control+page and have the controller send an email . see below
- Some of the systems settings can be changed remotely. Go the %Control+tab and enter the password %aquachiller+ and this will allow the user to send commands to the chiller.
- To change or set up the SNMP setting of the chiller go to the SNMP tab and log in using %aquasnmp+ and follow the instructions that appear on that page
- To change the passwords on the system to your own go to the access tab and log in using %echwater+. update with specific details and update.
- To update the customer name, address etc go to the customer tab and enter %aquacustomer+ as the password. The system will now allow you to update the site specific details

At anytime if passwords or IP addresses are lost then hold down the down button, the ESC and reset button at the same time and then release the reset button until the green LED next to the OK button comes on (about 4 seconds) will restore all the factory settings.

The system is now configured to the sites specific requirements.

BacNet and Modbus Communication with the BMS

If the unit is to communicate to the high level BMS using BACnet or Modbus then it will be supplied with an XML mapping file with the relevant OID points. **The installed firmware must be version P251_56_EB01_014 or higher.**

The AquaCooler P251 Pump and Transfer Control Unit runs the following Building Management System interface firmware:

- **SNMP V1 and V2C Agent (UDP port 161, Agent ID 33888, Read/ Write Community "public"),**
- BACnet IP Server (Optional), (UDP port 47808, Vendor ID 566, Initial Device Number 2012)
- Modbus TCP Server (Optional). (TCP port 502)

A single set of data points is accessed by all of these interfaces. The current set of data points comprises 32 read value (eg temperature inputs), 47 read/write value (eg set-points), 85 read binary (eg alarms), 5 read/write binary (eg BMS on/off), 2 write binary (eg clear all alarms). An xls spreadsheet mapping file documents the SNMP OIDs, BACnet objects and Modbus Holding Register cross connection. Using the SNMP OIDs as a basis, this cross connection is programmed into the Pump and Transfer controller via the uploading of a text based xml file derived from the mapping file.

INSTALLATION

Without a valid xml mapping file uploaded into the controller, only the SNMP Agent will be operational. All SNMP OIDs have remained unchanged from previous Pump and Transfer firmware releases so that firmware containing the latest BACnet and Modbus interfaces will still be able to be accessed by an alternative, external SNMP to BACnet and Modbus gateway such as the Babel Buster.

To enable the BACnet IP and Modbus TCP local servers:

1. Obtain the relevant xml mapping file from AquaCooler.
2. Log onto the control unit local web server as 'admin'.
3. Navigate to 'advanced' 'upload' page.
4. Browse your connected PC for the correct xml mapping file.
5. Enter the upload password "aquaupload".
6. Press the 'Upload New File' button and wait for the acknowledgement screen.

The 'Upload has been Successful' page should then appear. This indicates that the correct file had been checked and saved on the control unit. If the upload was not successful then the file chosen may not be the correct format or type. In this case please refer to AquaCooler technical support for assistance. Following the successful upload of the mapping file, the file is automatically saved in non-volatile memory and all data points should then be available to the external BMS via SNMP, BACnet IP or Modbus TCP

The SNMP, BACnet IP and Modbus TCP interfaces provide full control, monitoring and configuration of the Pump and Transfer Unit via the mapped data points. All of the interfaces are IP based and share a single 10/100Base-T ethernet physical layer which is also shared with the local HTTP web server. As such, an SNMP, BACnet IP or Modbus TCP client that is running on an external BMS will need to 'point to' the Pump and Transfer Current Local IP address. This IP address can be found by pressing the 'up' key once on the control unit from the home screen. IP ports for connection are standard for each service (shown above).

Connection to the SNMP V2C agent requires correct community names (shown above). Connection to BACnet IP requires a correct device number (instance) also shown above. This device number can be changed by going to the local web server 'Chiller ID' page and changing the BACnet device number shown.

All data points can be accessed via BACnet 'Objects'. Analog Inputs, Analog Outputs and Analog Values and Binary Inputs, Binary Outputs and Binary Values only are implemented. Object numbers begin at 1 and the maximum number of each data point is shown in notes on the Web Server 'Upload' page. In general the standard BACnet Read property and Write Property services are available on Analog Output, Analog Value, Binary Output and Binary Value objects. BACnet Read Property services are available on Analog Input and Binary Input objects. BACnet Read Object Name is also available on all objects. Mandatory object properties are implemented but most optional object properties are not. Present value priority arrays are not implemented for Analog Values or Binary Values. Other optional object properties and some BACnet services may not be available from the local server. Unimplemented properties will respond with a BACnet 'Unknown Property' error message and unimplemented services will respond with a BACnet 'Service Unavailable' error message.

INSTALLATION

All data points can also be accessed via Modbus 'Holding Registers'. Register numbers for Analog objects can be calculated by multiplying the hundreds, tens and units portion of the localreg number by two, subtracting one then adding 40,000 and the thousands portion of the localreg numbers on the xml mapping file (for example, an analog value object localreg number 2003 would be Modbus holding register $2*3 - 1 + 2000 + 40,000 = 42,005$). Register numbers for Binary objects can be calculated by adding 40,000 to the localreg numbers on the xml mapping file. Registers are 16 bits long and so 32 bit real (Analog 32 bit floating point) values are transmitted as two successive 16 bit registers in 'big endian' format. Should 32 bit analog real values received from the Pump and Transfer Modbus TCP interface be unintelligible on an external BMS then the external BMS may be attempting to send/ receive 32 bit real values with the registers in reverse order. In this case a 'Modbus Register Swap' tick box can be set by going to the 'Network' page of the Pump and Transfer control unit local web server and following the 'Save Network Config' procedure.

Local Register numbers 2001 to 2999 are Analog Value Objects mostly comprising set-points that allow the BMS to adjust operating points of the Pump and Transfer unit as necessary. To be able to change these values SNMP data point 1.3.6.1.4.1.33888.1.6.2.3.0 - 'P264ControlSetSetparenable' must be set to 1 if the 'Network' page 'Set-Point Enable Restrict' tick box is checked. If the 'Network' page 'Set-Point Enable Restrict' tick box is unchecked, full backward compatibility is maintained with existing Babel Buster interfaces that may simply write any value to 'P264ControlSetSetparenable' to give a 5 minute window for set-point edits.

The 'Network' page 'Set-Point Enable Restrict' tick box also affects 1.3.6.1.4.1.33888.1.6.1.1.0 - 'P264ControlResetRemalmreset' and 1.3.6.1.4.1.33888.1.6.1.2.0 - 'P264ControlResetRemsysreset' in a similar way.

Before start up ensure that;

- **The water circuit is complete to and from the process and that it has been properly leaked checked and bled of any air in the system.**
- **Check that power has been supplied to the chiller in order that the sump heaters have had enough time to warm the sump oil.**
- **In a tandem installation ensure that the master chiller and the slave chiller are wired the correct way around. See wiring diagram.**

Remote Condenser Installation

R Series Chillers can be ordered in configurations featuring the ability to remotely mount the condenser in order to permit maximum installation flexibility. When ordered with a remote condenser configuration we deliver the condenser and the chilling unit separately. Both the chiller and the condenser are *pre-charged* with refrigerant and fitted with isolation valves.

The distance from the chiller to the condenser should be kept as small as possible. Excessive distance lead to high refrigerant pressure drops which in turns leads to loss in chiller capacity. We recommend that the condenser should be located no more than 9m vertically from the chiller, and the total refrigerant piping should be kept less than 20metres. However for long refrigerant pipe runs between chiller and condenser pipe size can be increased to compensate for losses.

INSTALLATION

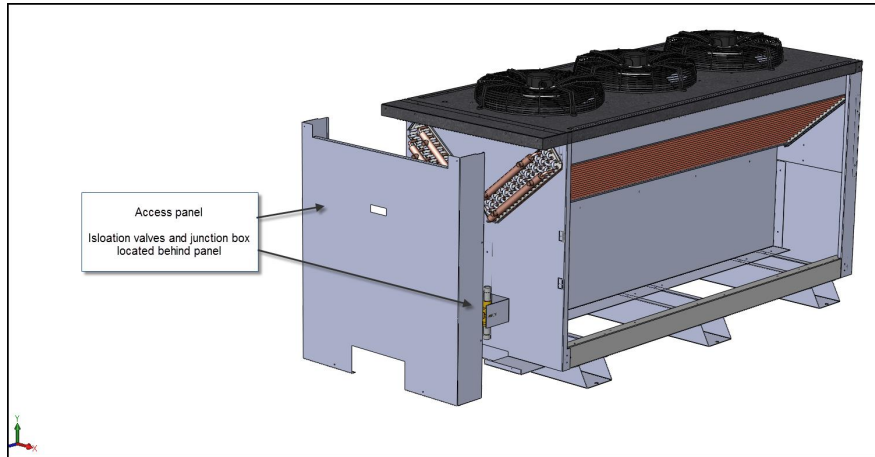

Recommended pipe sizing for extended pipe runs

There are indications only. Final pipe sizing should be site specific and installed by qualified refrigeration mechanic.

	R420AR-R670AR	R830AR-R1200AR
Discharge Line	3/4"	3/4"
Liquid Return Line	1/2"	5/8"
Electrical Connection	2 * 3 Core + E 1mm ² or 1 * 6 Core + E 1mm ²	

R1500 to R2500				
Pipe Run - m	7.5	15	30	45
Discharge Line	1 3/8+	1 5/8+	2 1/8+	2 1/8+
Liquid Return Line	1 3/8+	1 5/8+	1 5/8+	2 1/8+
Electrical Connection	4 core + E 1mm			

For pipe runs longer than 20 meters an oil separator or trap may have to be installed . please contact Aqua Cooler for recommendation on installation on pipe runs longer than this.

The condenser is fitted with a junction box switch into which the electrical supply from the chiller must be connected. Both the chiller and the condenser are fitted with refrigerant isolation valves with flare connections.

It is essential to provide suitable protection preventing inadvertent contact with the discharge and liquid return lines. Both these lines can get extremely hot and direct contact may cause burns. Aqua Cooler accepts no responsibility for any injuries resulting from the refrigerant connection pipes.

It is essential that a suitably qualified refrigeration mechanic connects the refrigerant piping between the chiller and the condenser.

INSTALLATION

Unit with interal buffer tank



Once the refrigerant lines have been connected between the condenser and the chiller it is essential to pressurise the lines with nitrogen and check for leaks. Once cleared of leaks the the lines should be evacuated. This can be performed at either the condenser or the chiller by attaching leads to the appropriate schrader valve on the refrigerant isolation valves. There should be no need to add additional refrigerant to the lines as long as the lines do not exceed 9m in total length. Once evacuated and charged (if necessary) the shut off valves can be opened.

Remove the access panel to gain access to the junction box and the isolation valves.

There are two major stages in commissioning the electrical circuit. First is to ensure that the supply phase sequence is correct at the chiller. The second is to ensure that the subsequent connection between chiller and condenser does not reverse the phase sequence.

To confirm the phase sequence at the chiller it is necessary to check the direction that the pump motor turns. A directional arrow is shown on the rear of the pump motor to assist in this task. Ensure that there is water in the system and turn the pump on. If the pump turns in the wrong direction then correct the phase sequence at the supply isolation switch and not within the chillers electrical enclosure.

Under no circumstances is ducting to be attached to the condenser fan outlets. When installing beneath a ceiling do not mount the condenser upside down, instead use brooker rods or similar to support the condenser.

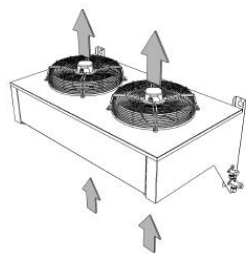

Vertical Discharge Configuration

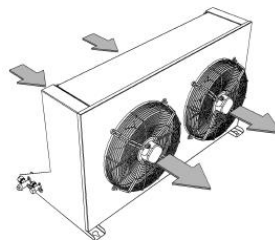

Horizontal Discharge Configuration

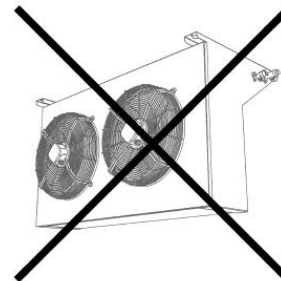

Incorrect Horizontal Discharge Configuration

INSTALLATION

Once this task has been completed the fan direction should be checked. It will be necessary to organize somebody to view the operation of the fans at the condenser. Gain access to the electrical enclosure by removing the panel above the water fitting on the refrigeration module. Press and hold down each of the fan contactors and confirm that the fans are sucking air through the condenser and exhausting it off the fans themselves as shown by the arrows in previous images. If incorrect then rectify the sequence at the isolating switches on the condenser.

Before starting up the chiller have the following installation requirements been carried out

- Has the unit got proper ventilation
- Was the pressure on the suction gauge above 300kPa before filling the unit with water
- Is the bypass in the tank left open
- Is the power supplied to the unit in accordance with the requirements
- Has air been bled from the water path
- Has the electrical circuit been energised for at least 4 hours to allow the sump heat to warm the compressor oil.

INSTALLATION

Multiple Chiller Installations

Aqua Coolers chiller can be installed in multiple installations for redundancy or to allow scaling as process application increases in size . for example adding power to a data centre.

There are some requirements for the installation to prevent issues when the chillers duty cycle or if a chiller develops a fault and the central controller or BMS starts another one.

The requirements are

- The chillers must be ordered with the flood back option . this hydraulically isolated the chiller when it is in standby mode. There is a motorised ball valve on the return water line and a check valve on the water outlet line
- A drain header must be installed between the chillers. This allows the water level in all the chillers to be same. Obviously this will not work if the chillers are installed at different levels.
- The controller in the chiller has a high water temperature alarm acknowledge delay. This setting needs to be set to at least 2 minutes. When the chillers duty-cycle the water sitting in the tank of the standby chiller can get warm especially on warmer days and when the chiller starts up the high temperature alarm will activate . this alarm delay will give the chiller time to start cooling the water and allow cold water in the pipe work to stir the tank. See the service and maintenance section of the manual on how to change this setting.

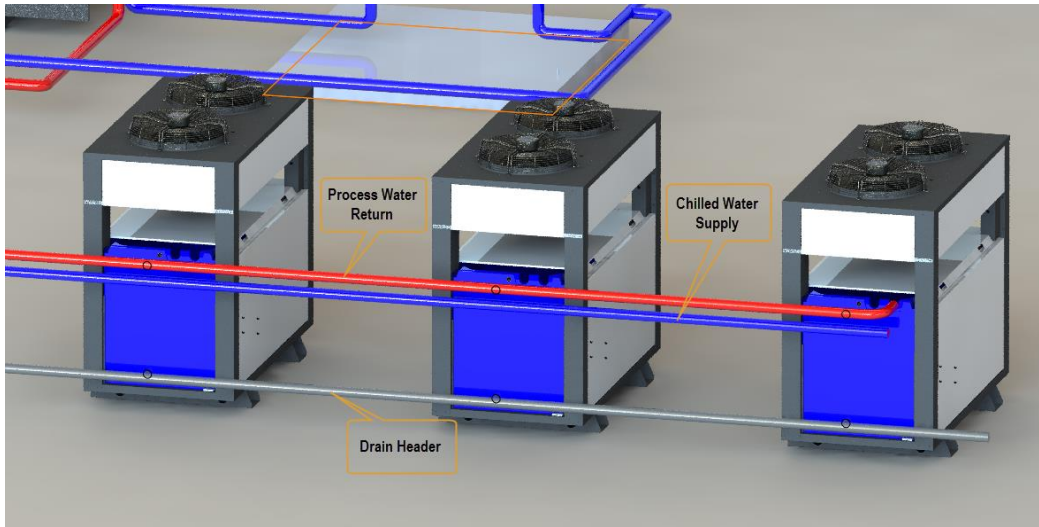

Standard Aqua Cooler chiller can be installed together in pairs and one of the chillers will act as the master and the other the slave and the master will duty cycle the chillers and keep a healthy. If there are more than two chillers Aqua Cooler can supply a central chiller controller to monitor and duty cycle the chillers

OPERATION

Before starting the chiller, ensure that the pressure on the suction pressure gauge on the front of the chiller is above 400kPa. If the pressure is below this then there may be a leak in the refrigeration circuit and water may be drawn into the refrigeration circuit on start up. If the pressure is below this then it is recommended that the chiller be inspected before filling the tank with water.

The unit is ready to be started up. Once power is provided to the chiller, open the clear plastic guard over the ON/OFF switch and turn the unit on and the unit will start automatically. The pump will start immediately and the controller will start measuring the flow rate to check that the pump is running normally.

The water bypass on the chiller will be supplied fully open.

The compressors have a two minute start delay. Once the compressors have cut in the watch the display to ensure that the water temperature is coming down.

Operational parameters that are displayed on the screen

- Water temperature T1, Return Water Temp T2, Ambient temperature T9
- Primary water flow
- Heat load
- Compressor run time

Any faults are indicated on the face of the control panel.

It is a good idea after the unit has been running for 5 minutes check that the water temperature is dropping and check there are no bubbles in the sight glass . if these two things are happening then the unit is running properly. Give the system a final check to ensure that there are no water leaks. An amp meter can also be run over the wires into the contactors to ensure that the compressor and the pump are drawing the right amount of amps according to the technical data. Close the guard over the ON/OFF switch and screw into place to prevent passersby shutting down the chiller.

CONTROL

AQUA COOLER CONTROLLER

Operational logic is as follows

Start up . Pump ON, Ball Valve OPEN (if fitted), 10 second delay and then flow readings are taken to check pump is running normally.

After compressor hold time and set point plus hysteresis COMP1 ON

If water temperature reaches set point then compressor OFF. Unit then waits for both the hysteresis and compressor hold time again and then starts compressor.

Temperature Control – Set Point

Compressors will turn compressors off when the set point is breached. Compressors will be turned on again at temperature plus hysteresis

Temperature Control - Max and Min Set Point

This prevents casual operator from setting supply temperatures too high or too low

CONTROL

Temperature Control - High and Low Temperature Alarm Stop

High and low temperature limits can be set in order that if they are breached then the chiller will shut down. In very rare instances a component may fail without triggering any of its internal fault indicators. The chiller may think it is running normally yet not refrigerating. It is recommended that high and low temperature stop is set to yes to prevent this happening.

Fan Speed Control - Optional

The controller monitors the discharge pressure of each of the refrigeration circuits and makes decisions for fan speed based on this value.

There are 3 ways to control the fans and the settings can be changed in the controller.

ON ZERO FULL . The fans can be set to shut down while the compressor is running. If the pressure drops below the minimum set point . say on a cold day . then the fans will shut down to prevent over condensing even though the compressor may still be running.

ON LOW FULL - In the menu there is a valve for minimum run (default 1500 kPa) which when reached will start the fans and run them at 20% speed. There is a fan full speed setting (default 2200 kPa) that will run the fans at full speed. The fan speed will then run proportionally between these two values. These operational pressures will be different for units supplied with R134a . see the setting section of the manual

OFF FULL SP ONLY - this will have the fans off when the compressor is off and full speed when the compressor is on.

The default will be the middle option

High Pressure Control

The system will monitor the discharge pressure of each of the refrigeration circuits and will send a warning when the pressure starts to get too high. If the alarm pressure is breached then it will shut the unit down. It will do this 3 times in a 24 hour period before shutting the chiller down permanently. There compressor wiring circuit has an automatically re-setting high pressure safety switch installed and set at 2800 kPa for R407 gas and 2200 Kpa for R134a. But setting the controllers alarm above these settings the automatically resetting HP safety switch will allow the chiller to keep re-starting until something fails in the chiller.

If the chiller is to be installed in redundancy . that is with another chiller in tandem or with multiple chillers and controlled by a BMS or the Aqua Cooler central control system, this feature will de-activated.

Water Flow/ Pump Control

The system monitors flow rates and will send a warning if a flow rate is breached and shut the chiller down if the flow alarm point is breached. Zeroing the flow alarm turns it off. It is recommended that the flow alarm is not turned off.

The pump can be set to run if the chiller develops a fault . by turning this feature ON in the program will keep water to the process. This water will of course get warm but it is designed to keep the process cool long enough for system shut down

CONTROL

If the unit is supplied with a redundant pump the controller will shut the pump down when it detects a problem with the flow. The pump sitting in redundancy will be started. If there is a problem with the flow on this pump it will be shut down and the original pump started.

This process will happen 3 times in 24 hours before the unit is shut down permanently.

Every week the pumps are duty cycled to share the wear and tear on the units.

Compressor Hold Time

The controller will wait 120 before starting compressors up after shut down to prevent too many start ups.

Alarm Acknowledge Delay

This delay is the time that the program waits before flagging an alarm. This may be useful in the event of a tandem switch over to a tank of very warm water for example. If the water is too warm then the high water temperature alarm may be triggered. If there is a delay then it will give the newly activated chiller time to pull the water temperature down.

Pump Delay Time

The controller will wait this time before taking flow reading . it is designed to give the ball valve time to open before indicating flow problems

High Ambient Control

If the high ambient water spray kit is fitted then the system will spray the condensers with water once air on temperature is breached AND the fans are running. The water spray will turn off once the ambient temperature has dropped or the fans have stopped running.

Tandem Control

One chiller will need to be assigned a master chiller and the other a slave chiller . see the service section for instructions on doing this. The master chiller will do all the controlling and timing. Output 16 (status) on the control board will be energised while it is running closing the indicated input (enable) on the standby chiller not allowing it to run. After a week the output will de-energise and the standby chiller will run . its output 16 energising closing the input on the now standby chiller.

The rest of the control settings and the default setting for the parameters outlined above are outlined below . it is recommended that they are not altered without consulting Aqua Cooler

The settings below are the only ones that should be altered by the operator . the rest of the menu are for setting up the chiller and should not be altered. The controller also has some options not relating to this model of chiller.

CONTROL

Close tolerance

If the unit has been manufactured for close tolerance then the controller will attempt to keep the water temperature within the close tolerance number around the midpoint between the set point and the hysteresis.

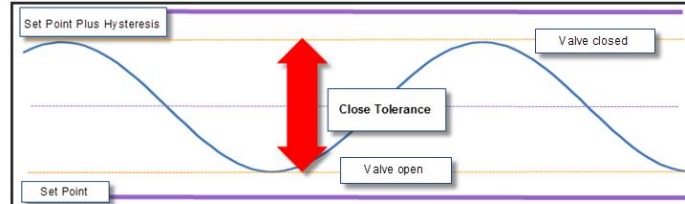

For example if the set point is 10 degrees, the hysteresis 2 and the close tolerance 1 degree then the controller will attempt to keep the temperature between 10.5 and 11.5 degrees.

The ability of the chiller to keep the temperature as close to the set point will vary depending on heat load. The closer the heat load is to the chillers rated capacity the more accurate the chiller can maintain the close tolerance. Under low loads the chiller will be unable to maintain less than 1°C close tolerance

Variable Speed Compressor Control

At set point plus approximately 1 degree the compressor will run at 50% and at approximately 2 degrees above this, as decided by the PID algorithm; the compressor will run at 100%. In between these points the system will run a fully integrated PID loop to maintain temperature control . it will be taking temperature measurements every 0.5 seconds and controlling speed accordingly.

For the compressor installed the full speed is 75Hz.

NOTE . the close tolerance function and the compressor load chare options should be switched off if a VSD is fitted to the compressor.

Low Load Control

This is an optional feature and can be turned on and off. The controller will be monitoring the amount of start-ups the compressor is going through. If there are too many then the controller will temporarily widen the hysteresis. The compressor should not go through more than 10 start ups per hour. By widening the hysteresis then the stat up will reduce and this will prolong compressor life. If the system it going to be lightly loaded it is recommended that this option be turned on.

Putting the unit in standby mode

<p>Using the key pad the unit can be put into standby mode if there is a reason to shut the unit down for a short amount of time.</p>	<ul style="list-style-type: none"> • Scroll through the menu to find %EYPAD STANDBY+ • Press %OK+and then %OK TO CONFIRM+The unit will stop running • The screen will be showing %OK TO RE-START+and %EYPAD STANDBY MODE+will be flashing • Press %OK+and the chiller will go through its normal start up procedure
---	---

THIS DOES NOT TURN THE UNIT OFF AND THE ELECTRICAL CIRCUITRY INSIDE THE ELECTRICAL BOX WILL STILL BE LIVE

CONTROL

CONTROL – STANDARD CONTROLLER

Temperature Control – Set Point

Compressors will turn compressors off when the set point is breached. Compressors will be turned on again at temperature plus hysteresis

Temperature Control - Max and Min Set Point

This prevents casual operator from setting supply temperatures too high or too low

Compressor Rest Time

The controller will wait 120 before starting compressors up after shut down to prevent too many start ups.

SERVICE and MAINTENANCE

Warning: Always isolate the power from the chiller prior to working on the unit.

Warning: Always ensure that personnel have read and understood the SAFETY section of this manual prior to working on the chiller.

Warning: When the mains controller is de-energised the power contactors are live, even if the components are not operating.

All maintenance must be carried out by qualified refrigeration mechanics.

These units have been designed for the minimum of maintenance. However to ensure optimum performance qualified personnel should carry out regular maintenance. A comprehensive preventative maintenance program is available through Aqua Cooler carried out by qualified refrigeration mechanics.

Should any faults be identified then please call Aqua Cooler to arrange a service call.

Recommended preventative maintenance program

Operation	Frequency
Refrigerant Charge	6 Monthly
Electrical connections are tight	6 Monthly
Compressor amp draw	12 Monthly
Pump amp draw	12 Monthly
Condenser strainer cleaned	6 Monthly

Unlocking the keypad on the Aqua Cooler controller

IMPORTANT NOTES

- The key pad on the smart controller will lock out after 10 minutes of non-use. To unlock the key pad press the ESC, DOWN, UP and ESC keys in sequence

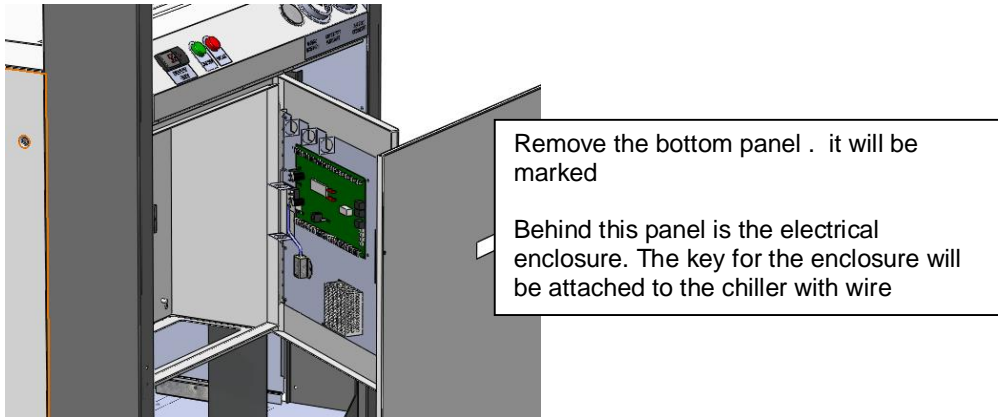

SERVICE and MAINTENANCE

Accessing the electrical box – standard chiller**Aqua Cooler Controller Maintenance****Data Logging**

The chiller is automatically storing data on its operational parameters and performance. In the event that there is a problem with the chiller this data may become useful for diagnosis.

Downloading Data from the Controller

The operational data can be downloaded from the controller by either using a USB flash drive or via the hyper link terminal (RS232). There are two types of files on the system . and event log and a time log. The event log takes reading every time there is an event change, compressor on or off for example. The time log saves data every set time period. The default is every 10 minutes but this can be set as low as every 2 minutes. At 10 minutes intervals there is over a week of data saved on the board. The parameters that are logged are the supply, return and ambient temperatures, the suction and discharge pressures and the water flow rate. All changes of state are also logged on the inputs and outputs. Using this data is a good way to check the effective running of the chiller and to help with diagnosis when a service visit is needed.

Download via hyper link . A laptop with Windows Hyper- terminal installed will be needed to download the files. Connect your laptop via a RS232 cable to the outlet marked RS232 on the printed circuit board controller in the electrical enclosure

1. Find Program, Accessories, HyperTerminal. Run this on your laptop
2. Select Hyper-terminal File Open and choose the P223xxx.HT file attached.
3. Select Hyper-terminal Transfer Capture Text and choose a file name to save the log to
4. GO to the Chiller board Parameter menu and choose %log DLOAD RS232+Then Enter
5. Up arrow to choose one of the 4 download options then Enter. Hyper-terminal should be displaying the data as it is received. This may take up to 20 minutes.
6. Close Hyper-terminal to save the file then repeat steps 7 to 10 for the 3 remaining log downloads.

SERVICE and MAINTENANCE

Download via USB . insert a USB key into the USB key on the rear of the circuit board controller.

1. Go to the PARAMETERS MENU and press OK and then scroll to MANAGE LOG DATA sub menu and press OK
2. There a number of options . the most useful are TIME LOG TO USB and EVENT LOG TO USB. Press OK and the data will start to upload . the screen will confirm when the process is complete.
3. The process has to be done twice . once for each file.
4. Putting the USB into a computer will show the folder labelled %AQUA+and inside this will be a excel data file. The excel file will have labels for all the data that has been logged . the newest data will be at the top.

NOTE: the shorter the time between readings the less history the system can record. 10 mins should give approximately 3 weeks of data logging . 10 second intervals will only give 24 hours of data logging and the logging drops the old files off the end so if the unit has a problem and it takes more than one day to get to site then the relevant data will be gone.

The second way of downloading the data is via the webpage . to the %advanced+tab on the webpage and then to the download tab . the drop down list will then give you the option of downloading the files.

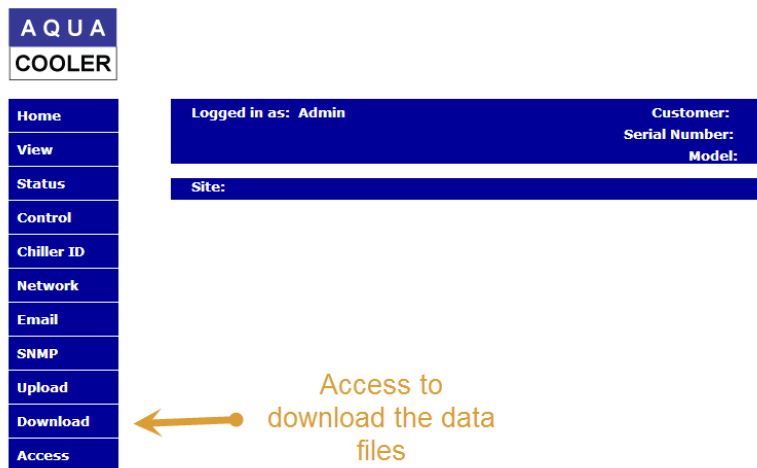

The controller will ask you to save the file somewhere.

Email Alarms – Aqua Cooler Controller

The chiller can also be programmed to send emails in the event of a problem and this data log will be emailed as at the same time . see the installation section on setting this up and it will have to be turned on in the parameters menu of the program.

Inside the electrical box the controller will be mounted on the door. In the middle if the controller, next to the LCD screen, there are four red buttons. These buttons are used to program the chiller. They are marked up, down, OK and esc.

SERVICE and MAINTENANCE

Calibration of Sensors – Aqua Cooler Controller

The temperature sensors will be calibrated before dispatch but in the even one needs to be replaced then it is a good idea to recalibrate the sensors as they effect the operation of the chiller.

1. Scroll through the controller to parameters menu
2. Scroll down to the Sensor Menu sub- menu
3. Scroll through to the ambient, supply or return calibration
4. Place the sensor and a calibrated thermometer together and allow the temperature to settle
5. Press OK and the value will flash. Use the up and down scroll buttons to calibrate the sensor to the thermostat and press OK again
6. Exit the program

Updating Software

The chiller is dispatched with the latest firmware always installed however should a software upgrade be required then it can be done simply by installing a USB stick into the USB port at the rear of the controller.

The firmware will be emailed and it will have a HEX extension at the end of the file. The file will be U264_32_EB4_XXX.hex.

Upload this file onto the USB stick making sure it is the only HEX file in the root directory of the USB stick.

Insert the stick into the USB port on the rear of the Aqua Cooler controller . the controller will look for the file automatically and start the upload. The screen will confirm upload in progress and confirm when it is complete. It should take about 15 seconds. None of the setting in the controller will change except the feature that the upgrade is improving, adding or fixing.

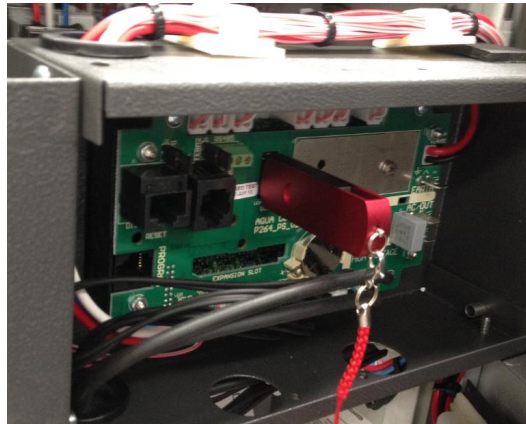

For units that are connected to the internet or to a BMS system the BIN file will need to be updated as well to the corresponding issue number. Using a laptop connect to the Aqua Cooler controller via the Ethernet card in the rear of the controller.

SERVICE and MAINTENANCE

Open a browser with <http://10.1.1.130:8076/mpfsupload> OR if the controller has already been configured to a unique IP address then use this address. Use the BROWSE key to retrieve the BIN file saved to your computer or USB key. Once this is uploaded the page will show a tab with %Site Main Page+on it. Click on this and it will direct you to the main monitoring page for the chiller. The instructions are above for moving further into the control and monitoring of the chiller.

The IP address of the unit can be found by scrolling to the INFO menu on the home screen of the controller.

In the parameter menu there is time, date and year menu lines that can be set (see the service section for instructions) in order that the data log periods and the email alarms are time relevant.

THERE ARE OTHER PARAMETERS IN THE PROGRAMMING MENU – SOME ARE USED IN SOME OF THE OTHER OPTIONS – SOME NOT AT ALL. THEY SHOULD NOT BE ALTERED. ALTERING THE PARAMETERS NOT RELEVANT TO THE OPERATION OF YOUR CHILLER MAY AFFECT ITS PERFORMANCE AND REQUIRE AN OUT OF WARRANTY SERVICE CALL.

Changing the setting on the controller

If it is installed then the remote panel can be used to program the chiller otherwise remove the front panel of the chiller and open up the electrical box. Take precautions to ensure that none of the electronics or the switching gear can get wet. To change the programming parameters the circuit board will need power so it is recommended that the chiller is switched off using the green ON/OFF button on the front of the chiller.

By opening the electrical box the programmable circuit board controller can be seen mounted on the door. The four small red buttons next to the display are the buttons used for changing the parameters in the programming. The two buttons on the left are the up and down scroll buttons. The button top right is the OK button and the last button is the ESC.

Water Supply Temperature	
Setting the water supply temperature . Temperature that the refrigeration system with cut out	<ul style="list-style-type: none"> • Scroll to the parameters menu then to the set points sub menu • Scroll through the menu until %SETPT WATER TEMP+shows • Press %OK+ and %SET WATER TEMP+ will show and the water temperature will flash • Use scroll keys to adjust up or down and press %OK+again and %NEW WATER TEMP+will show <p>Press the escape key to revert to home page</p>

Temperature Hysteresis .	
Temperature between refrigeration circuit cut out and cut in Range 2 to 5 degrees	<ul style="list-style-type: none"> • Scroll to the PARAMETERS MENU then to the SET POINTS sub menu • Use scroll keys to find %TEMP HYSTERESIS • Default is 2 degrees . press %OK+ and SET TEMP HYSTER+ will show • Use scroll keys to change value and press %OK+ • %NEW TEMP HYSTER+will show • Press escape keys to return to home page • NOTE . hysteresis cannot be set below 2 degrees to prevent compressor short cycling

Compressor Hold Time .	
After the cooler has reached cut out temperature and the compressor will turn off. In order to minimise compressor starts there is a rest time. Range 5- 180 seconds	<ul style="list-style-type: none"> • Scroll to %PARAMETER MENU+ and then to the DELAY sub menu • Scroll to %COMP HOLD TIME+and press %OK+ • Value will flash and can be set to minimum of 5 seconds and maximum of 3 minutes . IT IS RECOMMENDED THAT THIS VALUE IS NOT ALTERED TO BELOW THE DEFAULT 2 MINUTES • Press %OK+and screen will confirm choice <p>Press the escape key to revert to home page</p>

SERVICE and MAINTENANCE

Maximum and Minimum Temperature Limits	
<p>This set a minimum and maximum temperature limit for the chiller and is there to prevent casual operators setting the supply temperature above or below recommended set points.</p> <p>Range -5 to 20 Min 10 to 30 Max</p>	<ul style="list-style-type: none"> • Scroll to the PARAMETERS MENU then to the SET POINTS sub menu • Scroll to %MIN TEMP LIMIT+or %MAX TEMP LIMIT+ • Press %OK+and %SET MAX LIMIT+will show will value flashing • Select choice and press %OK+and the screen will confirm choice • Press the escape key to revert to home page

High and Low Temperature Stop	
<p>High and low temperature alarm cut out . the unit can be set to go into standby if the high and low temperature alarms are breached and they will stay in standby until the fault is cleared by pressing the %OK+button</p> <p>Range Yes and No</p>	<ul style="list-style-type: none"> • Scroll to %PARAMETER MENU+then to the SYSTEM sub menu • Scroll to %HIGH TEMP STOP+ and %LOW TEMP STOP+ and press %OK+ • %SET HI TEMP STOP+will show with %YES+and %NO+manu choices • Change as desired, press %OK+and %STOP ON HI TEMP+will show confirming choice • Do same to change low temperature standby • Press the escape key to revert to home page

High and Low Temperature Alarm	
<p>High and low temperature alarm cut out . the unit can be set to go into standby if the high and low temperature alarms are breached and they will stay in standby until the fault is cleared by pressing the %OK+button</p> <p>Range Low -5 to 10 High 10 to 40</p>	<ul style="list-style-type: none"> • Scroll to %PARAMETER MENU+and to the SET POINTS sub menu • Scroll to %HIGH TEMP ALARM+and %LOW TEMP ALARM+and press %OK+ • %SET HI TEMP ALARM+will show temperature choices • Change as desired, press %OK+and %NEW HI TEMP ALM+will show confirming choice • Do same to change low temperature alarm • Press the escape key to revert to home page

Setting water flow alarms	
<p>Setting the alarm for the chilled water and condenser water flow . this setting when breached will place the unit into standby</p> <p>Range 0-5 l/s</p>	<ul style="list-style-type: none"> • Scroll to %PARAMETER MENU+and to the SET POINTS sub menu • Scroll to %LOW ALARM 1+ for chilled water supply and %LOW ALARM 2+for condenser water flow • Press %OK+and %CONFIG FL ALM1+will show with the value flashing • Change the value to where the warning needs to be and press %OK+. the alarm rate should be below the value of the warning • The screen will confirm your choice • Press the escape key to revert to home page
<p>Setting the waring for chilled water and condenser water flow. This setting will simply give a warning that the flow rate is dropping . the chiller will still run.</p> <p>Range 0-5 l/s</p>	<ul style="list-style-type: none"> • Scroll to %PARAMETER MENU+and press %OK+ • Scroll to %LOW WARNING 1+ for chilled water supply and %LOW WARNING 2+for condenser water flow • Press %OK+ and %CONFIG FL WARN1+ will show with the value flashing . as a rough guide the flow rates for the condenser water and the chilled water should be around 1.4 l/s • Change the value to where the warning needs to be and press %OK+ • The screen will confirm your choice • Press the escape key to revert to home page

Setting high pressure (HP) alarms and warnings	
<p>Controller will send out and warning at warning pressure and shut unit down at alarm pressure</p> <p>Range 2000 . 4000 kPa for both</p>	<ul style="list-style-type: none"> • Scroll to %PARAMETER MENU+and to the SET POINTS sub menu • Scroll to %HP Warn Press+ • Press %OK+and choices will be shown • Select choice and press %OK+and the screen will confirm choice • Press the escape key to revert to home page
	<ul style="list-style-type: none"> • Scroll to %PARAMETER MENU+and press %OK+ • Scroll to %HP ALM Press+ • Press %OK+and choices will be shown • Select choice and press %OK+and the screen will confirm choice • Press the escape key to revert to home page

SERVICE and MAINTENANCE

Setting fan speed control	
<p>If fan speed controllers are installed the minimum run speed (20%) and max run speed (100%) can be set again corresponding discharge pressures</p>	<ul style="list-style-type: none"> • Scroll to %PARAMETER MENU+ and to the SET POINTS sub menu • Scroll to %Fan Min SP Pressure+ • Press %OK+ and change required pressure • Select choice and press %OK+ and the screen will confirm choice • Press the escape key to revert to home page <p>The same procedure is followed to set %Fan Max SP pressure+</p> <p>Note . of fan speed controller are being retrofitted to a unit then the fan speed option will have to be activated in the parameters menu.</p>

Setting alarm acknowledge delay	
<p>Range 0-120 Minutes</p>	<ul style="list-style-type: none"> • Scroll to %PARAMETER MENU+ and press %OK+ • Scroll to %ALM ACK DELAY+ • Press %OK+ and change to setting • Select choice and press %OK+ and the screen will confirm choice • Press the escape key to revert to home page <p>It is recommended that the setting is not greater than 1 or 2 minutes</p>

Tandem Installation	
<p>Assigning the chillers into a single or tandem set installation</p>	<ul style="list-style-type: none"> • Scroll to %PARAMETER MENU+ and then to the SYSTEM sub menu • Scroll to %SINGLE/DUAL AUTO+ and press %OK+ • Change set up to %DUAL AUTO OPER+ and press %OK+ • The screen will confirm your choice • Press the escape key to revert to home page <p>NB . This only need be done on the master chiller</p>
<p>Assigning chiller role . Master or Slave</p>	<ul style="list-style-type: none"> • Scroll to %PARAMETER MENU+ and then to the SYSTEM sub menu • Scroll to %MASTER/ SLAVE+ and assign one chiller the master chiller and one chiller the slave chiller • Screen will show %SET MASTER/ SLAVE+ and change to whichever one is which and press %OK+ • The screen will confirm your choice • Press the escape key to revert to home page
<p>Duty Cycle Time</p>	<ul style="list-style-type: none"> • Scroll to %PARAMETER MENU+ and then to the SYSTEM sub menu • Scroll to %CYCLE CHANGEOVER+ and press %OK+ • %SET CYCLE PERIOD+ will show and the choices are %OFF+ where there will be no duty cycling at all but the chillers will still a ct in tandem . ie of one develops a fault it will start the other up. %10 MIN CYCLE TEST+ which will duty cycle chiller every ten minutes . this is more for installation testing and will revert to a weekly cycle after to 2 hours and %WEEKLY CYCLE+ which will duty cycle the chillers weekly. Note that if chillers are to switch at a set time every week then the timer will need to be set as mentioned above • Press the escape key to revert to home page
<p>Weekly Timer Reset</p>	<ul style="list-style-type: none"> • Scroll to %CYCLE TIMR RESET+ on the home screen • Press %OK+ and %ZERO CYCLE TIMR+ and %PRESS OK+ • %NEW CYCLE STARTED+ will show and the clock will reset • At any time during the week the timer can be viewed to see how long to changeover

SERVICE and MAINTENANCE

Full Setting List – again some of the settings are not for this model of chiller and it is recommended that THEY ARE NOT altered without a full understanding of the chillers programming or without checking with Aqua Cooler first. The settings reflect Aqua Cooler recommended setting for the installation ordered. If at a later time another chiller is installed in tandem or the chiller is added to a multiple chiller set then some of the setting may change.

PARAMETER MENU			
MENU ITEM	SETTING	MENU ITEM	SETTING
SYSTEM MENU			
SINGLE DUAL/OPN	Single	CLOSE TOLERANCE	OFF On for Close Tolerance Units
MASTER /SLAVE	MASTER SLAVE on chiller in redundancy	HIGH TEMP STOP	NO – set to YES only if warm water will damage process otherwise this will keep chiller running as long as possible.
CYCLE CHANGEOVER	NO in stand-alone installation YES on master chiller in N+1 installation	VAR SPEED FUNCTION	OFF On for chillers fitting with VFD on compressor or the pump
NO HE SENSORS	0	LOW TEMP STOP	YES
AUX INPUTS	N/O	FAN SPEED CONTROL	YES
SNMP DATA	Fractional	NETWORK CONTROL	OFF ON for chillers installed in networked installation
SPRAY COOL	OFF		
EMAIL LOG MENU			
EMAIL ALARM ON/OFF	OFF	MANAGE DATA LOG	OFF
DATA LOG PERIOD	1 MINS		
SET TIME MENU – Set all after install			
DELAY HOLD MENU			
ALARM ACK DELAY	0	COMPRESSOR HOLD TIME	120 SECONDS
UNLOAD HOLD TIME	15	PUMP DELAY TIME	20
SET POINT MENU			
PULL DOWN PER MIN	0.6	FAN MIN SP PRESSURE	1500 1200 on R134a
TEMPERATYRE HYSTERESIS	2	LP ALARM PRESSURE	150 80 on R134a
CLOSE TOLERANCE TEMP	0.1 if close tolerance function is activated	LP HYSTERESIS PRESSURE	200
HIGH TEMPERATURE ALARM	30	FAN MAX SPEED PRESSURE	2200 2000 on R134a
LOW TEMPERATURE ALARM	0	HP ALARM PRESSURE	2750 3000 on chiller installed with redundancy
HIGH RETURN ALARM	30	HP WARN PRESSURE	2600
LOW RETURN ALARM	0	LP WARNING PRESSURE	300 100 with R134a
MIN TEMP LIMIT	5	SUPPLY FLOW ALARM 1	0.1 l/s
MAX TEMP LIMIT	20	SUPPLY FLOW WARNING 1	Varies with pump supplied
SET PT AMB OTEMP	45	SET POINT TEMP	CUSTOMER SPECIFIC
SENSOR MENU			
CCT1 SUCT PR SIZE	0-10 BAR	SECONDARY SUPPLY CAL	SEE PROCEDURE
CCT1 DIS PR DISCH PR SIZE	0-30 BAR	AMBIENT CAL	SEE PROCEDURE
SUPPLY FLOW PIPE	DN 32	SECONDARY RETURN CAL	SEE PROCEDURE

SERVICE and MAINTENANCE

Controller Input and Output Schematic

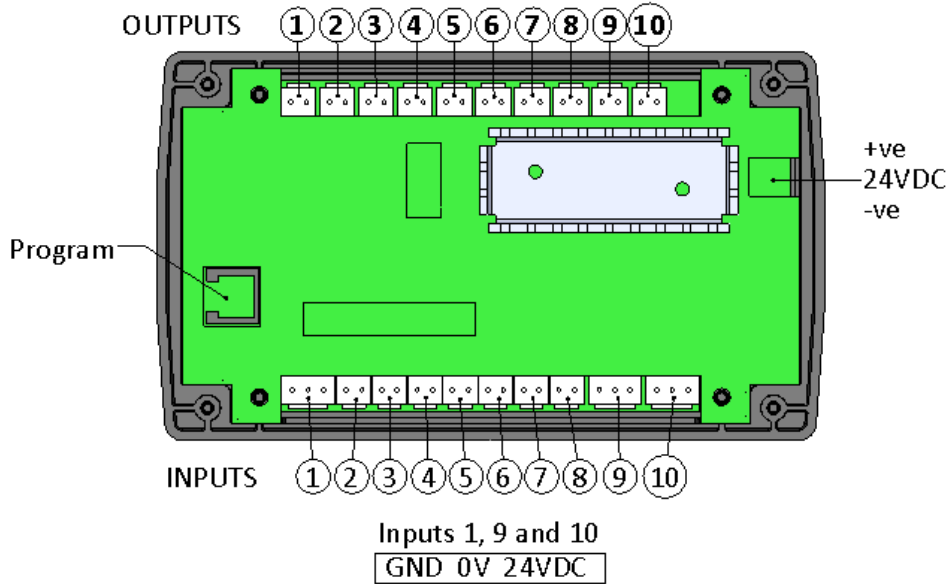

Connector	Type	Control
Outputs . 1 to 8 across the top of the board 0-10V Output 1 0-10V Output 2	24VDC 0-10 Volt out put 0-10 Volt out put	1 Compressors 2 Hot Gas/ Spray Cool 3 Pump 4 Ball Valve 5 Fan Bank 6 Master Fault 7 Master Run 8 Standby/ Tandem link enable/ Status 9 Variable Speed Compressor Control 10 Fan speed control
Inputs . 1- 24 across the bottom of the board IN1 IN2 IN3 IN4 IN5 IN6 IN7 IN8 IN9 IN10	0-10V Input 0-10V NC Input 0-10V NC Input 0-10V/ NTC thermistor 0-10V/ NTC thermistor 0-10V/ NTC thermistor 0-10V/ NTC thermistor 0-10V NC input 0-10V Inout 0-10V input	Supply Pump Flow Meter Compressor 1 fault input ON/OFF Switch Plate pack safety sensor Ambient temperature sensor Chilled water supply temperature sensor Chilled water return temperature sensor Standby/ Tandem link Suction pressure Discharge pressure

SERVICE and MAINTENANCE

Standard Controller Maintenance

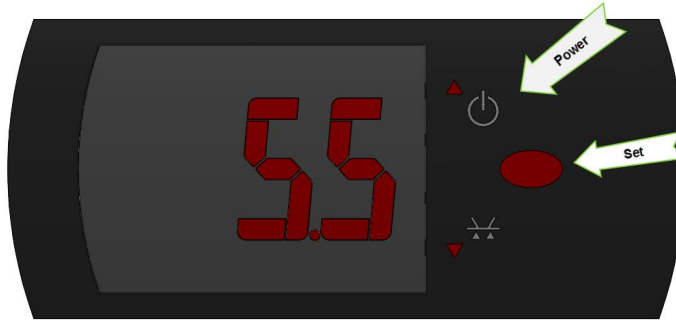

Changing the setting on a standard controller . the standard controller is on the outside of the chiller

1. Hold Power ON/OFF switch for 3 seconds
2. Press Set button for 1 sec to display temp set point
3. Change Set Point (St) to 5 degrees.
4. Hold Set button for 3 seconds to access parameter setting menu
5. To access password parameter (pS) Enter 22
6. Use arrow keys to scroll through parameters.
7. Set Parameters to the values below

r1: Min Set Pt allowed for user : 5°
 r2: Max Set Pt allowed for user: 25°
 r3: Operating Mode: 1 (no defrost)
 rd: set point differential (hysteresis): 2°
 c0: compressor rest time: 2 mins
 d0: defrost setting: 2

8. Press and hold Set button for 5 seconds to save settings and close.

RE/ VSD Range

The model of the chiller ordered will have postfix on the model with either VSD or RE. These models designate a chiller supplied with an inverter installed on the compressor to vary the speed of the compressor. The compressor, when running on anything other than full load, becomes more efficient. See the control section of this manual for the control logic for the drive.

The RE range of chiller will be running R143a refrigerant unless specified otherwise.

The power inverter receives a 2-10V signal from the Aqua Cooler controller and is factory set to run between 40 and 75Hz . that is at 2 volts the drive will be running the compressor at 40 Hz and at 10 volts 0r 100% the compressor will be running at 75Hz

Changing these setting should not be done without a thorough understanding of the chillers operation or without contacting Aqua Cooler or one of its license service agents.

The models of the inverter drive is listed below – more information on the drive can be found on the ABB website.

Chiller Model	Compressor Model	Drive Manufacturer	Drive Model
RE25/ RTDPC25	SZ300 Code 4	ABB	ACH550-01-059A

SERVICE and MAINTENANCE

Changing the filter cartridges

If installed it is recommended that the cartridges be changed every 9 to 12 months.

Remote Chiller

On the remote condenser the filter pack can be accessed by removing the panel at the opposite end of the unit to the electrical enclosure. Once the panel is removed, check the pressure gauges that can be seen in the front of the filter. If there is a difference in pressures on the two gauges then the filter may be blocking up and will need new cartridge.

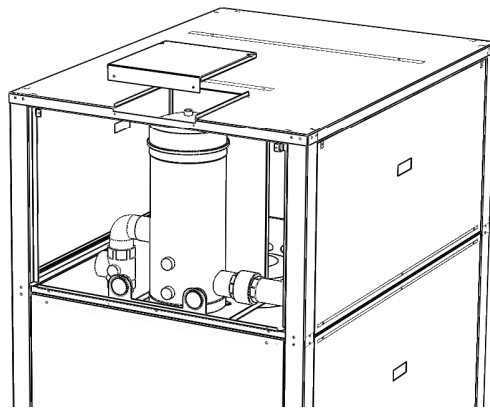

On the left hand side of the filter there is a two way valve . turn the handle to so it is pointing along the pipe with **FILTER BYPASS+** marked on it. Remove the access panel above the filter in the unit lid. In the front of the circlip around the lid of the filter housing there is a button that needs to be depressed before lifting the quick release lever. The lid can now be removed . doing so carefully in case of pressure build up. Lift the old cartridges out through the access hole in the unit lid and replace with new cartridges. Replace the lid on the filter housing and replace the circlip and tighten.

Turn the handle on the bypass ball valve back to the original position and check the system for leaks and check the pressures on the two gauges are similar.

Replace the access panel and the rear panel.

Standard Chiller

On the standard chiller the filter will be installed remote to the chiller. The bypass valve will be clearly marked.

Move the handle on the 3 way bypass valve so the handle of the valve is pointing towards the pipe marked **FILTER BYPASS+** Remove the circlip in the top of the filter housing slowly in case of pressure build up and remove the lid of the filter. Change filter cartridges and replace filter lid and ensure circlip is tight. Move the handle on the 3 way bypass valve back to the original position and check the pressure on the gauges that are located next to the filter are reading the same pressure to indicate there are no blockages in the system. Check for water leaks.

WIRING DIAGRAM . TANDEM INSTALLATION

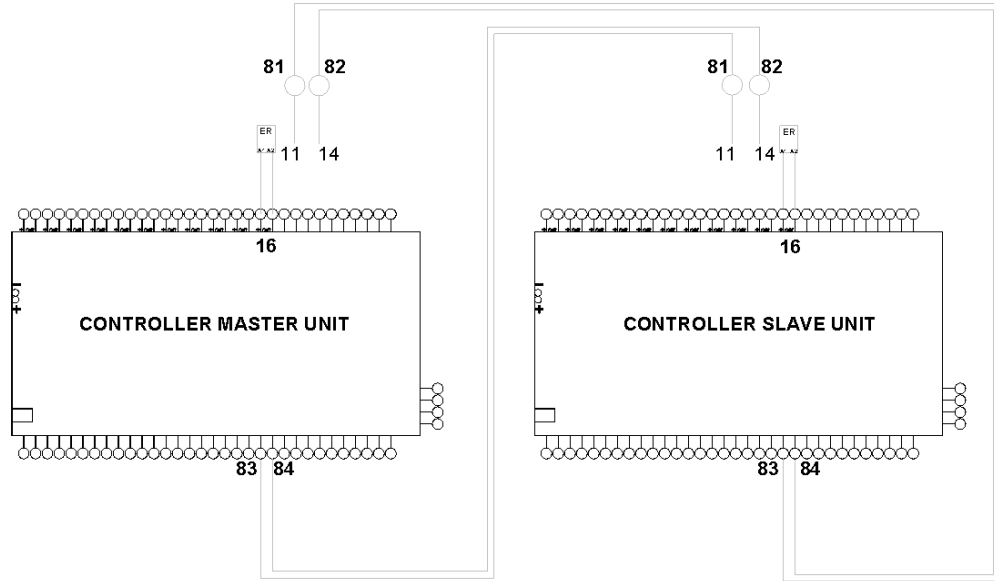

PUMP CURVES

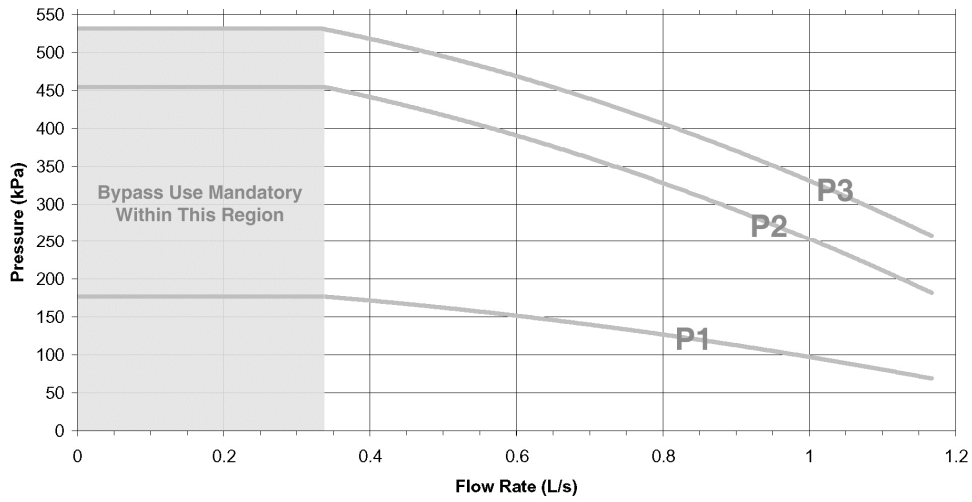

PUMP CURVES

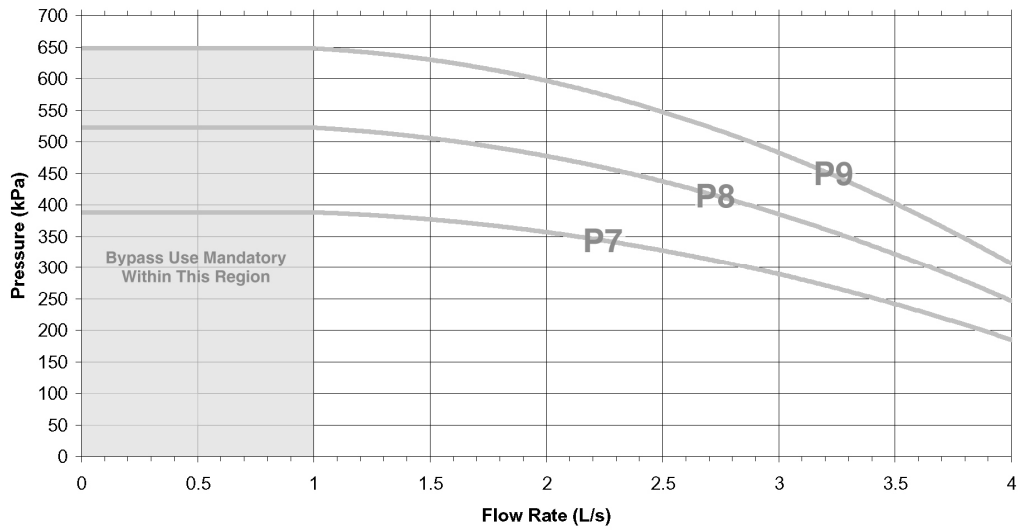
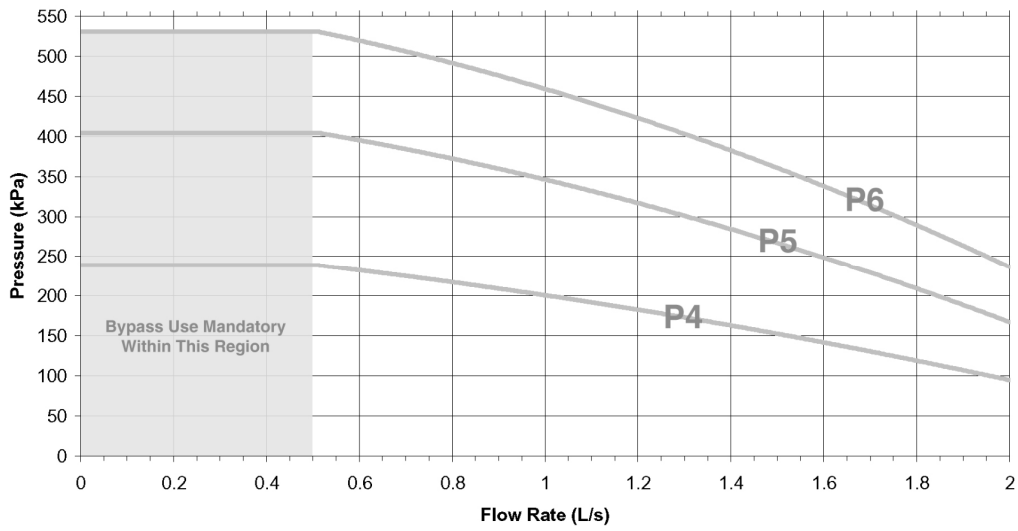

CRITICAL SPARE PARTS

Electrical spare parts are listed on the wiring diagram . contact Aqua Cooler for the parts required for the model of chiller. To maintain the smooth operation of the chiller only quality suppliers should be used for spare parts. Aqua Cooler maintains stock of all critical spares but if they need to be sourced locally then the list below are approved suppliers

Component	AC Part No
Compressor	Danfoss or Copeland
Fans	EBM Papst
Switching gear	ABB
Pumps	Lowara
Heat exchangers	Aqua Cooler or SWEP for BPHE
Motorised ball valves	Belimo
Pressure transducers	Schneider
HP/ LP switch	Sagiomya . most local distributors
TX valves	Danfoss
Sight glass/ drier	Danfoss
Flow meter	Burkett

DATA SHEETS

Fan Data Sheet

<http://img.ebmpapst.com/products/datasheets/W6D800GO0101-ENG.pdf>

Compressor data sheet

<http://doc.3c-e.com/danfoss/odsg/pdf/FRCC-UD-100115-041841.pdf>

Pump data sheet

<http://www.lowara.com/lowdata/doc/EN/ceaca-td-en.pdf>

Flow meter data sheet

http://www.burkert.com.au/products_data/datasheets/DSS030-Standard-EU-EN.pdf

Plate heat exchanger

<http://www.swep.net/index.php?tpl=productsheets&lang=en&id=361&Type=V&Size=120T&Material=SC&Pressure=M>

TROUBLE SHOOTING

In the event the chiller develops a fault then the fault is displayed on the screen readout on the control board. The faults displayed are comprehensive but not fully descriptive.

Symptom	Possible Causes/ Solutions
Low Flow Alarm and pump fail	<p>Faulty Pump</p> <p>Replace Pump ensuring new pump has been leak tested, phase wiring is around the right way See below for installation http://www.lowara.com/lowdata/doc/ml/surface-im-xx.pdf See below for technical data</p>
	<p>Blocked plate heat exchanger</p> <p>Isolate the chiller and attempt to back flow through the plate pack Replace if the plate pack has become chronically blocked See below for data sheet Faulty electrical contactorϕ . check operation and replace if necessary</p>
	<p>Faulty flow meter . remove the head of the flow meter and check that the paddle wheel has not become blocked</p>
	<p>Work Around . If the pump seems like it is functioning and the flow rate is low then zeroing the flow alarm will allow the pump to run until the cause of the alarm can be found.</p>

High Pressure alarm	<p>Check head pressures when the unit is running. Possible causes blocked condenser . check for dust or debris build up and clean</p>
	<p>Dead or dying fan . check amp draw of fans or air flow. Replace if needed</p>
	<p>Too high a heat load for the rating of the unit. Check install and site specifications</p>
	<p>Bad installation or too high ambient . check that there is no other equipment in the vicinity that may be throwing heat onto the unit or that the unit has not been installed improperly</p>

Compressor Fault	<p>Low pressure alarm may have tripped</p> <ul style="list-style-type: none"> • Flow rate from pump may be too low . check pump settings and requirements • System may have lost refrigerant gas • TX valve may have seized <p>Motor protection module in compressor tripped</p> <ul style="list-style-type: none"> • Motor running too hot . return water may be too high . in-rush of heat load <p>Motor protection module tripped</p> <ul style="list-style-type: none"> • Compressor drawing too much current
------------------	--

HEX Under Temp	<p>This the plate heat exchanger back up temperature probe reaching 3 degrees while the refrigeration circuit is running</p> <ul style="list-style-type: none"> • Primary temperature (supply) probe has failed • Load has suddenly dropped off chiller
----------------	---

WIRING DIAGRAM

A wiring diagram unique to the chiller will be in the electrical box with this manual . if it has not been provided please contact Aqua Cooler to organise a copy.

Legend for component marking in the electrical box/ wiring diagram			
CTOL	Compressor Thermal Overload	C	Compressor contactor
CER	Compressor enable relay	P	Pump contactor
PER	Pump enable relay	F	Fan contactor
FER	Fan enable relay	FVSD	Fan variable speed drive
HGBV	Hot gas bypass valve relay	PTOL	Pump thermal overload
FTOL	Fan thermal overload	MPM	Motor protection module
FSC	Fan speed controller	CSS	Compressor soft starter
CB	Circuit breaker	TSTAT	Thermostat
FMCB	Fan motor circuit breaker	CMCB	Compressor motor circuit breaker
PF	Phase failure relay	LP	Low pressure switch
HP	High pressure switch	ER	Enable relay
PMCB	Pump motor circuit breaker	PVSD	Pump variable speed drive

RELEASE NOTES

RELEASE - SOFTWARE		
Date	Issue	Description
01/11/11	A	Document release as a generic manual Software to version P264_56_E00_009
01/01/12	B	Software to version P264_56_E00_010
13/03/12	C	Software to version P264_56_EB0_011
06/06/12	D	Software to version P264_56_EB0_13
05/11/12	E	Chiller firmware P264_64_EB4_014
08/01/13	F	Chiller firmware P264_64_EB4_014
09/01/13	Not released	Chiller firmware P264_64_EB4_015
07/02/13	G	Chiller firmware P264_64_EB4_016AA
15/12/13	G	Chiller firmware to P264_64_EB4-206
02/04/14	G	Chiller firmware to P264_64_EB4_207

RELEASE - HARDWARE		
Date	Issue	Description
06/06/12	D	Lordan coils introduced on all models April 12 Switching gear supplier changed from March 12 SE Pressure transducer introduced from June 12

COMMISSIONING

It is important that the chiller is commissioned in accordance with the guidelines below in order to ensure proper and trouble free operation.

Outlined below is a check list showing all the considerations that must be taken for the proper installation and operation of the chiller.

Pre-start checks

Procedure	Carried out in accordance with procedure?	Notes
Check that there has been no evidence of damage from transport		
Has adequate clearance been left around and above the chiller as per the instructions outlined in the installation section		
Check that the isolation switch has been installed close to the chiller in line of sight		
On standard chillers and remote condenser models ensure that the power connection to the chillers and between the modules is protected		
Note down the pipe run from the chiller to the process.		
Note down the water pipe sizes to and from the chiller		
Has the water pipe work been fitted with insulation		
Check the refrigeration circuit for oil residue and run a leak detector over the refrigeration system.		
On remote condenser model note the distance between the two modules		
On remote condensers note the refrigeration pipe sizes between the two modules.		

Electrical Connection

<i>Isolate power to the chiller</i> and access the electrical box and check all wiring is tight.		
---	--	--

COMMISSIONING

Water Connection

Was the pressure on the suction gauge checked before the unit was filled with water . see Installation		
Open the mains make up water to the chiller . has all the air been bled from the system		
Check the water path for leaks		

Start Up

Press the ON/OFF button on the front of the chiller and the pump will start up

After adding power to the chiller, change the water temperature setting and all other alarms to customer or site needs		
After chiller has started check and note down the current draw for the compressors, pump and fans		
Note down the water flow reading		
Note down pump pressure		
Does pump performance fall on the respective pump curve		
Check the sight glass for evidence of bubbles or moisture		
Check that water temperature is dropping		
Note down the oil level on the compressor sight glass		
Adjust the bypass valve to suit customer and/ or site needs		
Fit gauges and note down running pressures on the chiller		

COMMISSIONING

Tandem Installation Checks

On the master chiller set the cycle time to 10 minute test+ and after 10 minutes check that the chillers duty cycle.		
Fault the running chiller and check the other chiller starts and vis-a-versa		

Finishing Off

Is the electrical box closed and door secure		
Are all panels secure		
If the mesh was removed from the side of the chiller has it been replaced		
Are all tools and debris clear of the site		
Are there any site specific feature that may hinder the operation of the chiller in the future		

Notes

SITE INSPECTION

Proposed Chiller Model:		Date Inspected:	
		Inspected By:	
		Company:	
		Contact Number:	

Business Name Of Installation Site:	
Installation Site Street Address:	
Installation Site Phone Number:	
Installation Site Facsimile Number:	
Installation Site Contact Name:	
Installation Site Contact Position:	
Access Limitations: Any issues relating to service access including after hours access, induction course requirements, hot works permits, confined spaces, safety harness requirements	
Equipment Serviced By Chiller:	

SITE INSPECTION

Chiller Installation – Clearances			
<p><i>Mark out any condensing units or other possible heat sources that may effect the operation of the proposed chiller installation</i></p> <p><i>Highlight any walls/fixtures/items that encroach on the clearances required for the chiller installation.</i></p>			
<p style="text-align: center;">Insert Drawing and photo of site here:</p>			
Minimum Space Requirements:			
Chiller Model	Actual Foot print	Space Required around chiller.	
R Series I	975L x 590W x 1060H	600(E) x 2000(H)	
R Series II	975L x 590W x 1060H 1495L x 790W x 1340H	800(E) x 2000(H) 800(E) x 2000(H)	
R Series III & T Series	2015L x 860W x 1545H	800(E) x 2000(H)	
R3000	2585(L) x 1400(W) x 1830(H)	1000(E) x 2000(H)	
R3000 Condensing Unit	2135(L) x 1400(W) x 1680(H)	1000(E) x 2000(H)	
R3000 Refrigeration Unit	1200(L) x 970(W) x 1510(H)	600(E) x 2000(H)	
H Series	2020(L) x 1610(W) x 1600(H)	1000(E) x 2000(H)	
L Series	2010(L) x 1780(W) x 1600(H)	1000(E) x 2000(H)	
Chiller Installation - Continued			
Isolation Switch:	YES/NO	Drainage Provided:	YES/NO

SITE INSPECTION

Chiller Water Circuit Requirements			
Notes:			
Pipe Size:		Pipe Insulation:	
Length:		Height Difference:	
Balancing Valve:	YES/NO	Isolation Valves:	YES/NO
Water Treatment:	YES/NO	Make Up Water:	YES/NO
Treatment Used:			
Supply Pressure:		Flow Rate:	
Pressure Tap Points:	YES/NO	In Line Filtration:	YES/NO

Remote Condenser Requirements			
Notes:			
Pipe Size:		Pipe Insulation:	
Length:		Height Difference:	

SITE INSPECTION

General Notes/Feedback	

Completion		
<p>Aqua Cooler uses the information from this site inspection sheet to confirm that the chiller will be installed and operating correctly. Should any problems or issues be raised as a result of the site inspection process then Aqua Cooler will take steps to address them with the customer, ensuring that the chiller operates reliably and without compromise to the long service life we expect of our products. We appreciate any feedback given as all data is used to influence our continual product development program.</p>		
Signature Of Service Agent	Print Name	Date
Signature Of Customer Representative	Print Name	Date

Filing – Aqua Cooler		
Signature	Print Name	Date Of Entry
Specify Follow Up Work Required:		