



Revision  
July - 2021



Thermal X - R Series

# Owner's Manual

This guide applies to the following models: R150 to R2500.



**Aqua Cooler Pty Ltd**  
U14, 2-12 Knobel Court  
Shailer Park 4128 Qld

[www.aquacooler.com.au](http://www.aquacooler.com.au)

1300 AQUA COOLER  
1300 278 286

# Table of Contents

Introduction.....	4
General Information.....	4
Denomination.....	4
Safety .....	5
First Aid .....	6
Installation Requirements .....	6
Installation of the Water Path.....	7
Water Connection Fittings by Model (Male BSPT) .....	8
Electrical Installation .....	8
Preparations For Starting the Chiller .....	8
Operating Sequence .....	9
Operating Precautions .....	9
CHLF2-60 .....	10
CHLF4-60 .....	10
CHLF12-40 .....	11
CDMF20-4.....	11
CDMF32-30.....	12
Aqua Cooler Controller.....	12
Unlocking the Keypad on the Aqua Cooler Controller.....	12
Operational Logic of Controller.....	13
Start Up .....	13
Temperature Control-Set Point .....	13
Temperature Control-Max and Min Set Point .....	13
Temperature Control-High and Low Temperature Alarm Stop.....	13
Fan Speed Control-Optional .....	14
High/Low Pressure Control .....	14
Water Flow/Pump Control.....	15
Compressor Hold Time.....	15
Alarm Acknowledge Delay.....	15
Pump Delay Time .....	15

Tandem Control .....	15
Close Tolerance.....	16
Full Setting List.....	20
Advanced Controller Functions .....	22
Downloading Data Log .....	22
Calibration of Sensors-Aqua Cooler Controller.....	23
Updating Software .....	24
Controller Input and Output Schematic .....	25
Poor Heat Dissipation .....	27
Low Refrigerant .....	28
Low and High Pressure Difference .....	28
Compressor Not Starting.....	28
Maintenance .....	28
Recommended Preventative Maintenance Program .....	29
Warranty.....	29
General Application .....	29
Installation Sketch Map of Air Cooled Chiller .....	30
Installation Sketch Map of Water Cooled Chiller.....	31
Internal Structure Sketch Map of Air Cooled Chiller .....	32
Internal Structure Sketch Map of Water Cooled Chiller.....	33
Commissioning Sheet .....	34
Notes .....	40

# INTRODUCTION

Thank you for choosing an Aqua Cooler chiller. In order to use this chiller correctly and efficiently, please read the following instructions in detail. This manual is designed to explain the installation, operation and the basic maintenance of the product. It is recommended that for service issues Aqua Cooler Pty Ltd be contacted before any work commences.

## General Information

The chiller is designed to refrigerate and circulate water to a heat developing process to aid in keeping that process cool. They are supplied with an immersed coiled evaporator, or plate heat exchanger, or shell&tube evaporator (model dependant), an air-cooled condenser and a rotary or scroll compressor to circulate the refrigerant gas. Water is circulated out of the unit via a pump. The chiller is designed to be installed outdoors and refrigerate water for a heat developing process – not for drinking or food preparation purposes. Any other use of this water chiller is not as it is intended.

## Denomination

<b>R1200A3-A-CC-CTO</b>					
					<u>Special Series:</u> None: Standard Unit CTO: Close Tolerance
					<u>Evaporator Type:</u> CC: Coil in Tank PP: Plate Pack ST: Shell&Tube
					<u>Refrigerant:</u> A: R134A C: R407C 410: R410A
					<u>Phase:</u> A1:Single-hase   A3: Three-phase
					<u>Model Number:</u> 150 to 2500
					<u>Chiller Series:</u> Thermal X R Series

## Safety



	<p><b>WARNING</b></p> <p>The unit is only to be installed, operated, maintained and serviced by qualified persons only. Operation of units such as these can be hazardous and should be serviced by persons with the proper training and qualifications. The unit and the Product Manual have markings, warning and instructions on the safe operation of the unit and they should be adhered to.</p>
---	---

This unit is designed to be safe in the use for which it was planned, provided that it is installed, started up and maintained in accordance with the instructions contained in this manual.

The unit contains electrical components that operate at line voltage and contains moving parts. It must be isolated from the electrical supply before being worked on. All maintenance operations that require access to the unit must be carried out by suitably qualified technicians who have a thorough understanding of all necessary precautions associated with refrigeration and electrical machinery. The unit is not to be used by the infirmed or children unless they are supervised by responsible persons qualified to carry out the supervision. All panels must be re-installed after carrying out any maintenance work. The unit should be secured to prevent it from toppling over.

Minimum temperature setting is 5°C on the unit. Any lower than this may cause problems with the evaporator icing up and potentially loss of refrigerant and potentially expensive service costs

The liquids to be cooled must be compatible with the materials used in the constructions of this unit. These liquids can be water or mixtures of glycol and water for example. The liquids to be cooled must not be flammable.

	<p><b>WARNING</b></p> <p>All wiring must be performed by qualified electricians. Improperly installed wiring and grounding may result in electrocution and fire hazards. To avoid these hazards all wiring must be installed in accordance with all the local relevant safety standards for wiring.</p>
	<p><b>WARNING</b></p> <p>The chiller contains refrigerants under high pressure. The system also contains oils under high pressure. Before the refrigeration circuit can be opened, the refrigerant should be reclaimed to reduce pressure in the system. Failure to recover the refrigerant to relieve pressure or the use of refrigerants or refrigerant substitutes that are not specified for the unit may result in system rupture and explosion.</p>

Refrigerants have a narcotic effect when inhaled in high quantities. Should a leak occur of the refrigerants then the room should be vacated and should only be re-entered after suitable ventilation.

R134A | R407C | R410A: Hazchem code 2RE and non – flammable.

## First Aid

<b>Eye Contact:</b>	Immediately flush with tepid water or sterile saline solution. Hold eyelids apart for 15 minutes while irrigating. Seek medical attention.
<b>Inhalation:</b>	Remove from the area of exposure immediately and if you are assisting a victim to avoid being exposed. Breathing apparatus must be worn in the presence of high concentration of refrigerants. If victim is not breathing then apply artificial respiration and seek urgent medical help. Give oxygen is available.
<b>Skin Contact:</b>	Cold Burns. Remove contaminated clothing and gently flush affected area with warm water (30°C) for 15 minutes. Apply sterile dressing and treat as for a thermal burn. For large burns immerse in water for 15 minutes. DO NOT apply any form if direct heat. Seek medical attention.
<b>Ingestion:</b>	For advice contact the poisons centre on 131126 in Australia. If swallowed do not induce vomiting. Ingestion is considered unlikely due to product form. Advice to Doctor. Use of adrenaline and other catecholamines may be contraindicated due to possible cardiac sensation. Treatment for asphyxia.

## INSTALLATION REQUIREMENTS

Immediately upon receipt of the chiller, carefully inspect the chiller for any damage that may have occurred in transit. Any such damage must be noted on the carrier's delivery documents. It is the consignee's responsibility to make any subsequent claims upon the carrier or respective insurance company. Any hidden damage should be reported to Aqua Cooler as soon as possible.

If the unit is to be stored before installation, then care must be taken to ensure no foreign matter can get into the water pipes. If the storage is for a prolonged period, it is recommended that the water circuit be changed with nitrogen and sealed.

A comprehensive commissioning program carried out by qualified refrigeration mechanics is available through Aqua Cooler. For full details and conditions please contact Aqua Cooler. There is also a site inspection procedure at the end of this manual.

The unit has been designed to be lifted with a forklift or a crane. The care must be taken when lifting with a crane that the strapping does not damage the side panels. The units are also designed to be moved around with a pallet jack, some models also have castor wheels.

The commissioning section at the end of this manual has a site inspection checklist designed to aid in checking that the site for the chiller installation is suitable. This should be filled out by someone experienced in chiller installation and returned to Aqua Cooler if there are any doubts about the installation. It is essential to ensure that adequate and safe service access to the chiller is provided. Failure to provide safe access to the chiller may lead to additional charges should servicing be required.

When installing indoors it is important to understand that the chiller will impart a significant heat load into the environment, and it is essential to ensure a plentiful, unrestricted supply of ambient temperature air to the chiller. Should you have concerns over the installation site then please contact Aqua Cooler for advice.

Note: Under no circumstances is ducting to be attached to the condenser fan outlet.

At least 800mm should be left around the unit (Rear: 1400mm) to allow for proper ventilation of the condenser. The unit should not be installed in a closed-off room. Preferably there should be no obstructions above the chiller, with a minimum of 2000mm clearance permitted in other circumstances. In addition to ensuring enough space around the chiller for free air movement, provision must be made around the chiller for service and regular maintenance. The chiller must be installed on a firm and level foundation, of adequate strength to support the chiller's full operating weight.

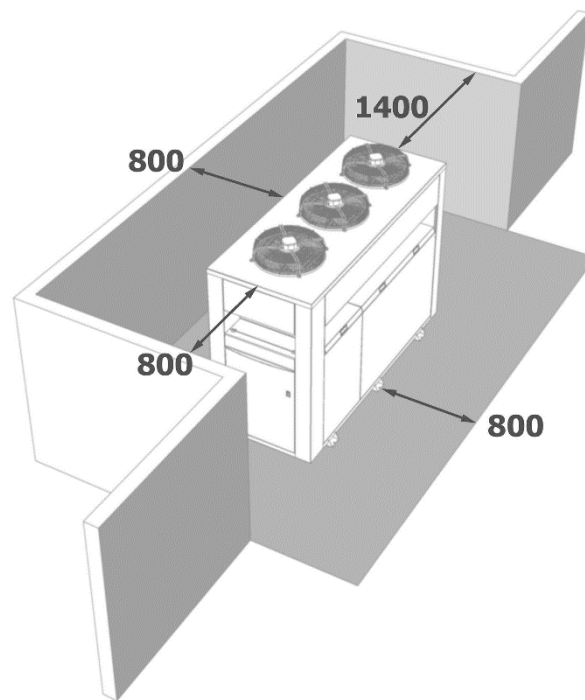

## Installation of the Water Path

Before connecting the make-up water, check the suction pressure on in the chiller to ensure there is no refrigerant leak. A refrigeration mechanic can do this with gauges or if the unit has a smart controller the pressure can be viewed on the display on the controller in the electrical box. If there is a leak in the refrigeration circuit, water may be drawn into the refrigeration circuit on startup. It is recommended that the chiller be inspected by a qualified refrigeration mechanic before filling the system with water.

All pipe work with refrigerated water running to and from the chiller should be fitted with water-resistant insulation material to prevent sweating and maximise the efficiency of the chiller.

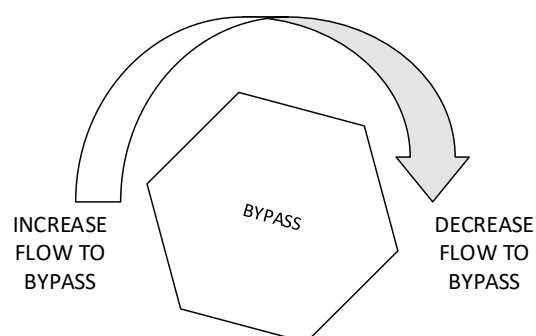

## Water Connection Fittings by Model (Male BSPT)

<b>Models:</b>	<b>R150</b>	<b>R420</b>	<b>R1330</b>
	<b>R180</b>	<b>R540</b>	<b>R1500</b>
	<b>R230</b>	<b>R670</b>	<b>R2000</b>
	<b>R300</b>	<b>R830</b>	<b>R2500</b>
	<b>R330</b>	<b>R1000</b>	
		<b>R1200</b>	
<b>Water Out:</b>	1"	1"	1½"
<b>Water In:</b>	1"	1"	1½"
<b>Drain:</b>	1"	1"	1"
<b>Overflow:</b>	1"	1"	1"
<b>Water Supply:</b>	½"	½"	½"

## Electrical Installation

The chiller draws a large amount of current and it is important that the connection of the unit to the power supply must be carried out in accordance with Australian standards and only by a licensed electrician.

The power supply system on-site and the circuit protection must be designed for the total current of the unit taking into account the inrush current and the lock rotor amps of the compressor— see the brochure. The circuit breaker must be set no more than 125% of the units rated load current.

Mains supply cables must be sized to ensure adequate voltage at the chiller under all load conditions. Three-phase power must be symmetrical, ensuring equal effective voltage and equal phase angle between consecutive phases. The pump and the compressor rely on correct phase rotation. Ensure all electrical connections are tight prior to starting up.

## PREPARATIONS FOR STARTING THE CHILLER

For the initial operation of the chiller, please confirm the following:

1. The power supply voltage and phase should be in accordance with the specifications listed on the chiller's marking plate.
2. Check the pipe and return water pipe are connected properly and the valve is open.
3. Fill the water tank with water or coolant before starting the water pump. (Ensure you are using a suitable coolant according to your requirements)
4. For water-cooled units, please pay attention to the moving direction of the water pump and confirm the tower fans are not moving in the opposite direction. If the pump is three-phase, change any two relative phase lines to reverse its direction. Then close the switch after connections have been made.



Before starting up the chiller have the following installation requirements been carried out

1. The power supply voltage and phase should be in accordance with the specifications listed on the chiller's marking place.
2. Check the ventilation of the unit.
3. Check the refrigerant leak through pressure gauge before filling the unit with water
4. Check the bypass in the tank. Make sure it's closed to ensure the water flow to application.
5. Check the power supply according to the requirements

## Operating Sequence

1. Open the valve of the supply pipe and return pipe and ensure the waterway is unimpeded.
2. Turn the unit on with the master power switch.
3. Press the run button on the interface panel to start the controller.
4. Press the compressor start button on the interface panel to start the compressor.
5. Pressing the power button while the unit is running will power off the unit.

The unit is ready to be started up. Once power is provided to the chiller, open the clear plastic guard over the ON/OFF switch and turn the unit on and the unit will start automatically. The pump will start immediately.

The compressors have a start delay. Once the compressors have cut in, watch the display to ensure that the water temperature is coming down. Set points and operational parameters are displayed on the screen. Any faults are indicated on the face of the control panel.

It is a good idea after the unit has been running for 5 minutes check that the water temperature is dropping and check there are no bubbles in the sight glass (if fitted) – if these two things are happening then the unit is running properly. Give the system a final check to ensure that there are no water and refrigerant leaks.

## Operating Precautions

1. Chilled water pump cannot be started without water in the water tank.
  - a. All standard models are equipped with water level protection in the water tank (except for closed water tanks). The default setting is when the water level is too low, the unit will throw an alarm and the pump will keep operate. However, this function can be changed in controller. Once the function is changed, pump will stop running if water level gets too low. Please make sure the function setting fits the application requirement.  
(Manufacturer Parameters – Control Setting – Low water lv. & Lack of water)
2. Switching the operating switches frequently should be avoided.
3. When the chilled-water temperature reaches the set temperature, the compressor will stop.
4. In order to prevent the evaporator freezing, do not set temperature below 5 °C (Except for sub-zero models)
5. When the unit is not in use for long periods of time, drain the tank
6. To ensure the most efficient operation, please clean the condenser, evaporator, and the water filter (if fitted) regularly.

# PUMP MODEL PUMP CURVES BY CHILLER

Chiller Model	Pump Model
R150, R180, R230, R300, R330	CHLF2-60
R420, R540, R670, R830, R1000, R1200, R1330	CHLF4-60
R1500, R2000, R2500	CHLF12-40

## CHLF2-60

Model	Driving Motor		Q(m <sup>3</sup> /h)	0.5	1.0	1.5	2.0	2.5	3.0	3.5
	(kW)	(hp)								
<b>CHLF2-60</b>	0.75	1	H(m)	54	50	48	42	38	33	25

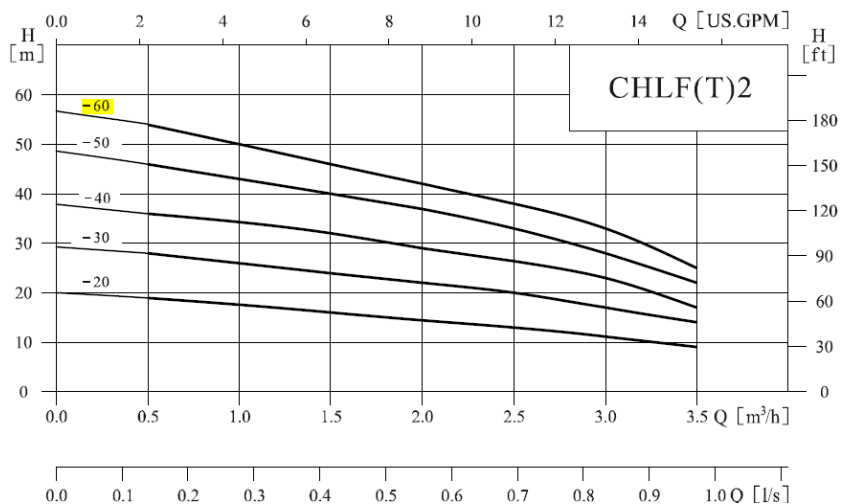

## CHLF4-60

Model	Driving Motor		Q(m <sup>3</sup> /h)	1	2	3	4	5	6	7
	(kW)	(hp)								
<b>CHLF4-60</b>	1.1	1.5	H(m)	55	53	50	45	37	31	26

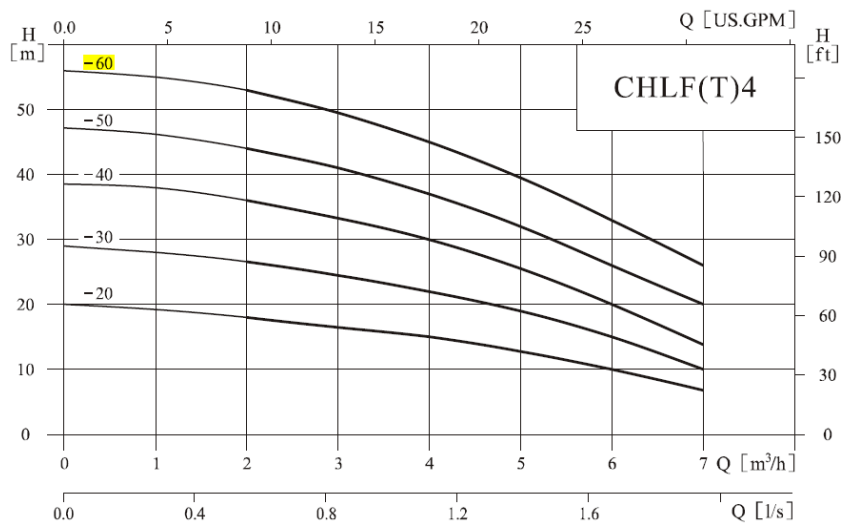

### CHLF12-40

Model	Driving Motor		Q(m <sup>3</sup> /h)	7	8	9	10	11	12	13	14	15	16
	(kW)	(hp)											
CHLF12-40	2.4	3.3	H(m)	47	46	45	43.5	41.5	39.5	37.5	35	31.5	27.5

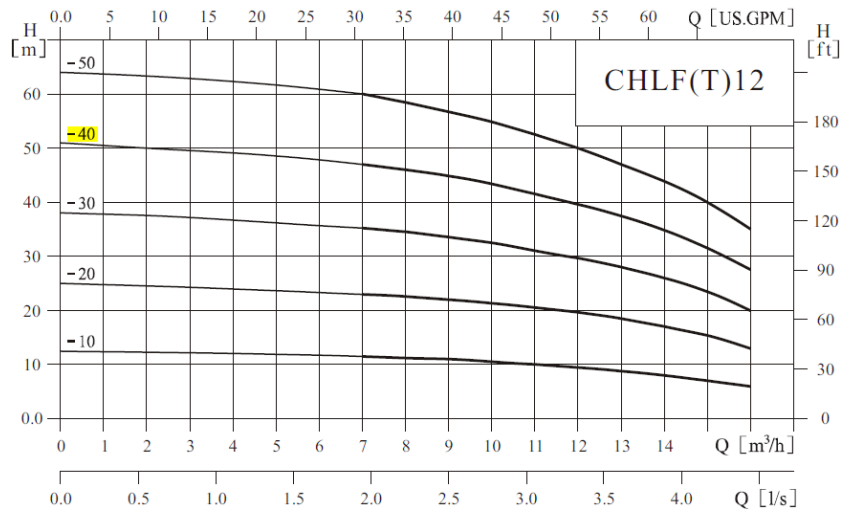

### CDMF20-4

Model	Driving Motor		Q(m <sup>3</sup> /h)	0	10	12	14	16	18	20	22	24	26	28	29
	(kW)	(hp)													
CHLF12-40	5.5	7.4	H(m)	55.5	52.5	51	50	49	48.5	47	45	41.5	37	33	31.5

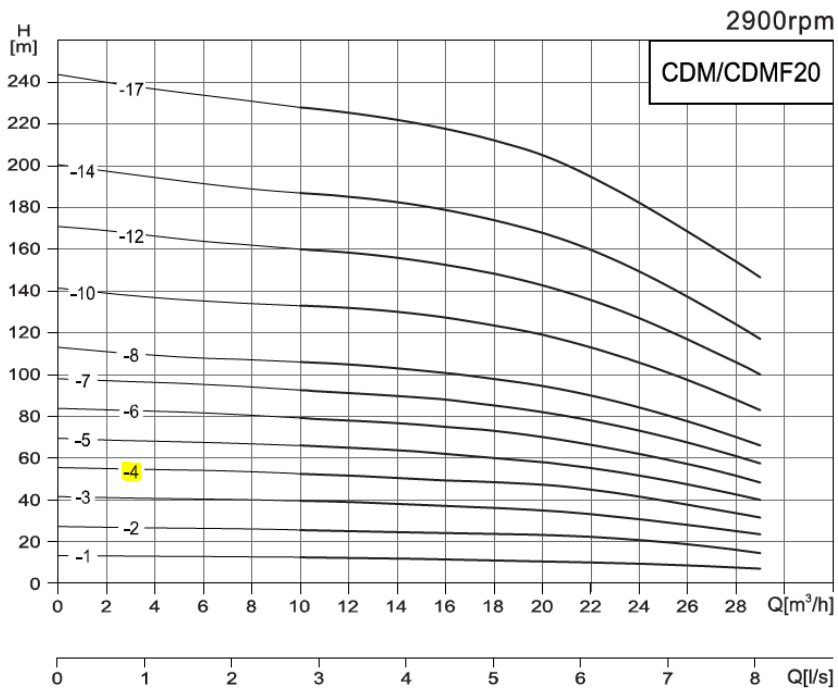

## CDMF32-30



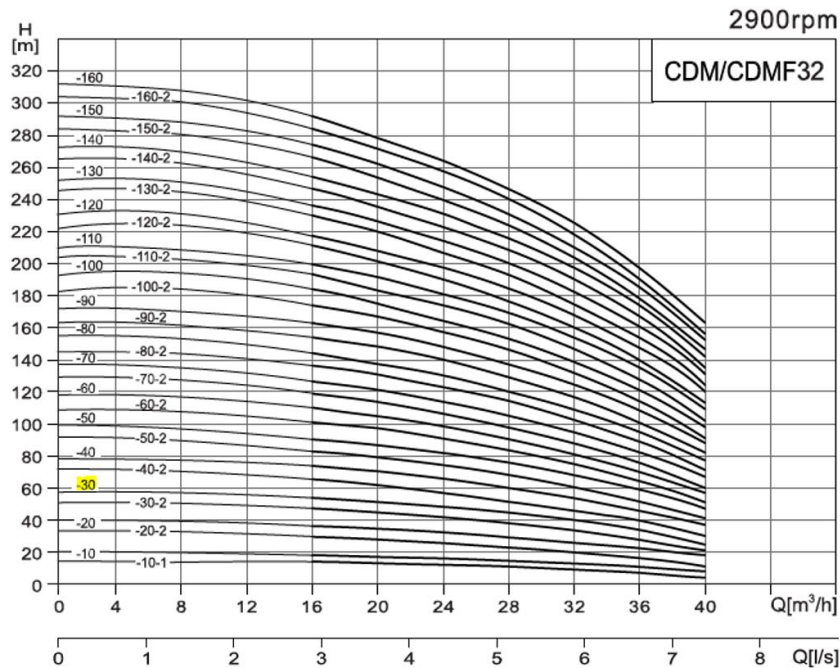

Model	Driving Motor		Q(m <sup>3</sup> /h)	0	16	20	24	28	32	36	40
	(kW)	(hp)									
CHLF32-30	55	7.4	H(m)	57	54	51	48	44	40	35	27



## AQUA COOLER CONTROLLER

The chiller unit features an interface panel with LCD display and input buttons to configure certain functions of the unit.

### Unlocking the Keypad on the Aqua Cooler Controller

The key pad on the smart controller will lock out after 10 minutes of non-use. To unlock the key pad press the [ESC] , [DOWN] , [UP]  and [ESC]  keys in sequence

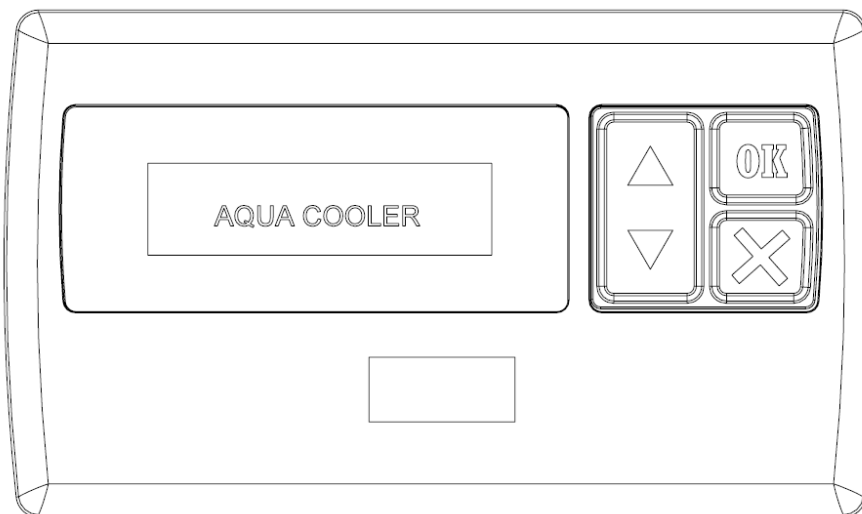

# OPERATIONAL LOGIC OF CONTROLLER

## Start Up

Pump ON, Ball Valve OPEN (if fitted), 10 second delay and then flow readings are taken to check pump is running normally. After compressor hold time and water temperature is above the set point plus hysteresis, COMP1 ON. Once the water temperature reaches set point then compressor OFF. Unit then waits for both the hysteresis and compressor hold time again and then re-starts compressor.

When there are two compressors such as model R3000 and R4000, the 2<sup>nd</sup> compressor will start after the set delay start time if required. The logic works as the system will start the 2<sup>nd</sup> compressor at the higher temperature than the 1<sup>st</sup> compressor after the delay time (hold time). This designed to give the lead compressor to handle the base load and subsequent compressor acts as a cooling capacity top up.

## Temperature Control-Set Point

Controller will turn compressors off when the set point is reached. Compressors will be turned on again once water temperature reaches set point temperature plus hysteresis.

## Temperature Control-Max and Min Set Point

This prevents casual operator from setting supply temperatures too high or too low

## Temperature Control-High and Low Temperature Alarm Stop

High and low temperature limits can be set in order that if they are breached then the chiller will shut down. In rare instances a component may fail without triggering any internal fault indicators. The chiller may think it is running normally yet not refrigerating. It is recommended that high and low temperature stop is set to yes to prevent this happening.

## Fan Speed Control-Optional

The controller monitors the discharge pressure of each of the refrigeration circuits and makes decisions for fan speed based on this value. There are 3 ways to control the fans and the settings can be changed in the controller.

**ON ZERO FULL:** The fans can be set to shut down while the compressor is running. If the pressure drops below the minimum set point – say on a cold day – then the fans will shut down to prevent over condensing even though the compressor may still be running.

**ON LOW FULL (Default option):** In the menu there is a valve for minimum run (default 1500 kPa) which when reached will start the fans and run them at 20% speed. There is a fan full speed setting (default 2200 kPa) that will run the fans at full speed. The fan speed will then run proportionally between these two values. These operational pressures will be different for units supplied with R134a – see the setting section of the manual

**OFF FULL SP ONLY:** This option has the fans off when the compressor is off and full speed when the compressor is on.

## High/Low Pressure Control

The system will monitor the discharge pressure of each of the refrigeration circuits and will send a warning when the pressure starts to get too high or too low. If the alarm pressure is breached, then it will shut the unit down. It will do these 3 times in a 24-hour period before shutting the chiller down permanently.

Thermal X		R134A	R407C	R410A
		Pressure	Pressure	Pressure
Aqua Cooler - PCB	HP	2300kPa [2200kPa]	2750kPa [2600kPa]	3500kPa [3300kPa]
	LP	80kPa [100kPa]	200kPa [300kPa]	100kPa [200kPa]
The chiller can only be restarted once pressure is back to a reasonable pressure: Warning pressure: [ __kPa].				

## **Water Flow/Pump Control**

The system monitors flow rates and will send a warning if a flow rate is breached and shut the chiller down if the flow alarm point is breached. Zeroing the flow alarm turns it off. It is recommended that the flow alarm is not turned off.

The pump can be set to run if the chiller develops a fault – by turning this feature ON in the program will keep water to the process. This water will of course get warm but it is designed to keep the process cool long enough for system shut down.

If the unit is supplied with a redundant pump the controller will shut the pump down when it detects a problem with the flow. The pump sitting in redundancy will be started. If there is a problem with the flow on this pump it will be shut down and the original pump started.

This process will happen 3 times in 24 hours before the unit is shut down permanently and every week the pumps are duty cycled to share the wear and tear on the units

## **Compressor Hold Time**

The controller will wait 120 seconds before starting compressors up after shut down to prevent too many start-ups.

## **Alarm Acknowledge Delay**

This delay is the time that the program waits before flagging an alarm. This may be useful in the event of a tandem switch over to a tank of very warm water for example. If the water is too warm then the high water temperature alarm may be triggered. If there is a delay then it will give the newly activated chiller time to pull the water temperature down.

## **Pump Delay Time**

The controller will wait for a certain time before taking flow reading – it is designed to give the ball valve time to open before indicating flow problems

## **Tandem Control**

One chiller will need to be assigned a master chiller and the other a slave chiller – see “CHANGING THE CONTROLLERS PARAMETERS” section for instructions on doing this. The master chiller will do all the controlling and timing. OUT8 (Standby: Tandem link enable/ Status) on the control board will be energised while it is running closing the indicated input (enable) on the standby chiller not allowing it to run. After a week the output will de-energise and the standby chiller will run – its OUT8 energising closing the input on the now standby chiller.

## Close Tolerance

If the unit has been manufactured for close tolerance then the controller will attempt to keep the water temperature within the close tolerance range around the midpoint between the set point and the hysteresis.

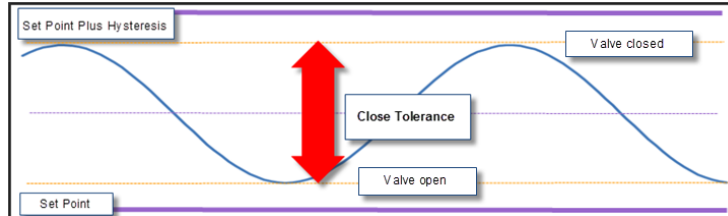

For example if the set point is 10°C, the hysteresis 2°C and the close tolerance 1°C then the controller will attempt to keep the temperature between 10.5°C and 11.5°C. The ability of the chiller to keep the temperature as close to the set point will vary depending on heat load. The closer the heat load is to the chillers rated capacity the more accurate the chiller can maintain the close tolerance. Under low loads the chiller will be unable to maintain less than 1°C close tolerance.

<b>Putting the unit in standby mode</b>	
Using the key pad the unit can be put into standby mode if there is a reason to shut the unit down for a short amount of time.	<ul style="list-style-type: none"> <li>• Scroll through the menu to find “KEYPAD STANDBY”</li> <li>• Press “OK” and then “OK TO CONFIRM” The unit will stop running</li> <li>• The screen will be showing “OK TO RE-START” and “KEYPAD STANDBY MODE” will be flashing</li> <li>• Press “OK” and the chiller will go through its normal start up procedure</li> </ul>
Note: This does not turn the unit off and the electrical circuitry inside the electrical box will still be live.	

Chiller achieves close tolerance control by using Aqua Cooler PCB to collect high pressure and low pressure data. PCB uses collected data to calculate suitable hot gas amount and send signal to hot gas solenoid valve.

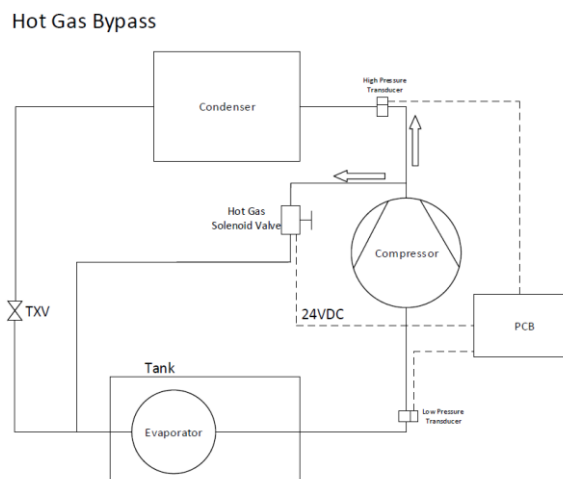



# CHANGING THE CONTROLLERS PARAMETERS

By opening the electrical box the programmable circuit board controller can be seen mounted on the door. The four small red buttons next to the display are the buttons used for changing the parameters in the programming. The two buttons on the left are the up and down scroll buttons. The button top right is the OK button and the last button is the ESC.

<b>Water Supply Temperature</b>	
Setting the water supply temperature – Temperature that the refrigeration system with cut out.	<ul style="list-style-type: none"> <li>• Scroll to the parameters menu then to the set points sub menu</li> <li>• Scroll through the menu until “SETPT WATER TEMP” shows</li> <li>• Press “OK” and “SET WATER TEMP” will show and the water temperature will flash</li> <li>• Use scroll keys to adjust up or down and press “OK” again and “NEW WATER TEMP” will show</li> <li>• Press the escape key to revert to home page</li> </ul>

<b>Temperature Hysteresis</b>	
Temperature between refrigeration circuits cut out and cut in.	<ul style="list-style-type: none"> <li>• Scroll to the PARAMETERS MENU then to the SET POINTS sub menu</li> <li>• Use scroll keys to find “TEMP HYSTERESIS</li> <li>• Default is 2°C – press “OK” and SET TEMP HYSTER” will show</li> <li>• Use scroll keys to change value and press “OK”</li> <li>• “NEW TEMP HYSTER” will show</li> <li>• Press escape keys to return to home page</li> <li>• NOTE – hysteresis cannot be set below 2°C to prevent compressor short cycling</li> </ul>

<b>Compressor Hold Time</b>	
After the cooler has reached cut out temperature and the compressor will turn off. In order to minimise compressor starts there is a rest time. Range: 5s to 180s	<ul style="list-style-type: none"> <li>• Scroll to “PARAMETER MENU” and then to the DELAY sub menu</li> <li>• Scroll to “COMP HOLD TIME” and press “OK”</li> <li>• Value will flash and can be set to minimum of 5 seconds and maximum of 3 minutes – IT IS RECOMMENDED THAT THIS VALUE IS NOT ALTERED TO BELOW THE DEFAULT 2 MINUTES</li> <li>• Press “OK” and screen will confirm choice</li> <li>• Press the escape key to revert to home page</li> </ul>

<b>Maximum and Minimum Temperature Limits</b>	
This set a minimum and maximum temperature limit for the chiller and is there to prevent casual operators setting the supply temperature above or below recommended set points. Range: -5°C to 20°C Min 10°C to 30°C Max	<ul style="list-style-type: none"> <li>• Scroll to the PARAMETERS MENU then to the SET POINTS sub menu</li> <li>• Scroll to “MIN TEMP LIMIT” or “MAX TEMP LIMIT”</li> <li>• Press “OK” and “SET MAX LIMIT” will show will value flashing</li> <li>• Select choice and press “OK” and the screen will confirm choice</li> <li>• Press the escape key to revert to home page</li> </ul>

<b>High and Low Temperature Stop</b>	
High and low temperature alarm cut out – the unit can be set to go into standby if the high and low temperature alarms are breached and they will stay in standby until the fault is cleared by pressing the “OK” button Range: Yes and No	<ul style="list-style-type: none"> <li>• Scroll to “PARAMETER MENU” then to the SYSTEM sub menu</li> <li>• Scroll to “HIGH TEMP STOP” and “LOW TEMP STOP” and press “OK”</li> <li>• “SET HI TEMP STOP” will show with “YES” and “NO” manu choices</li> <li>• Change as desired, press “OK” and “STOP ON HI TEMP” will show confirming choice</li> <li>• Do same to change low temperature standby</li> <li>• Press the escape key to revert to home page</li> </ul>

<b>High and Low Temperature Alarm</b>	
<p>High and low temperature alarm cut out – the unit can be set to go into standby if the high and low temperature alarms are breached and they will stay in standby until the fault is cleared by pressing the “OK” button            Range: Low: -5°C to 10°C            High 10°C to 40°C</p>	<ul style="list-style-type: none"> <li>• Scroll to “PARAMETER MENU” and to the SET POINTS sub menu</li> <li>• Scroll to “HIGH TEMP ALARM” and “LOW TEMP ALARM” and press “OK”</li> <li>• “SET HI TEMP ALARM” will show temperature choices</li> <li>• Change as desired, press “OK” and “NEW HI TEMP ALM” will show confirming choice</li> <li>• Do same to change low temperature alarm</li> <li>• Press the escape key to revert to home page</li> </ul>

<b>Setting Water Flow Alarms</b>	
<p>Setting the alarm for the chilled water and condenser water flow – this setting when breached will place the unit into standby            Range: 0-5 L/s</p>	<ul style="list-style-type: none"> <li>• Scroll to “PARAMETER MENU” and to the SET POINTS sub menu</li> <li>• Scroll to “FLOW ALARM 1” for chilled water supply and “FLOW ALARM 2” for condenser water flow</li> <li>• Press “OK” and “CONFIG FL ALM1” will show with the value flashing</li> <li>• Change the value to where the warning needs to be and press “OK” – the alarm rate should be below the value of the warning</li> <li>• The screen will confirm your choice</li> <li>• Press the escape key to revert to home page</li> </ul>
<p>Setting the warning for chilled water and condenser water flow. This setting will simply give a warning that the flow rate is dropping – the chiller will still run.            Range: 0-5 L/s</p>	<ul style="list-style-type: none"> <li>• Scroll to “PARAMETER MENU” and press “OK”</li> <li>• Scroll to “FLOW WARNING 1” for chilled water supply and “FLOW WARNING 2” for condenser water flow</li> <li>• Press “OK” and “CONFIG FL WARN1” will show with the value flashing – as a rough guide the flow rates for the condenser water and the chilled water should be around 1.4 l/s</li> <li>• Change the value to where the warning needs to be and press “OK”</li> <li>• The screen will confirm your choice</li> <li>• Press the escape key to revert to home page</li> </ul>

<b>Setting High Pressure (HP) Alarms and Warnings</b>	
<p>Controller will send out and warning at warning pressure and shut unit down at alarm pressure            Range: 2000 – 4000 kPa for both</p>	<ul style="list-style-type: none"> <li>• Scroll to “PARAMETER MENU” and to the SET POINTS sub menu</li> <li>• Scroll to “ HP Warn Press”</li> <li>• Press “OK” and choices will be shown</li> <li>• Select choice and press “OK” and the screen will confirm choice</li> <li>• Press the escape key to revert to home page</li> <li>• Scroll to “PARAMETER MENU” and press “OK”</li> <li>• Scroll to “ HP ALM Press”</li> <li>• Press “OK” and choices will be shown</li> <li>• Select choice and press “OK” and the screen will confirm choice</li> <li>• Press the escape key to revert to home page</li> </ul>

<b>Setting Fan Speed Control</b>	
<p>If fan speed controllers are installed the minimum run speed (20%) and max run speed (100%) can be set again corresponding discharge pressures</p>	<ul style="list-style-type: none"> <li>• Scroll to “PARAMETER MENU” and to the SET POINTS sub menu</li> <li>• Scroll to “Fan Min SP Pressure”</li> <li>• Press “OK” and change required pressure</li> <li>• Select choice and press “OK” and the screen will confirm choice</li> <li>• Press the escape key to revert to home page</li> <li>• The same procedure is followed to set “Fan Max SP pressure”</li> <li>• Note – of fan speed controller are being retrofitted to a unit then the fan speed option will have to be activated in the parameters menu.</li> </ul>

<b>Setting Alarm Acknowledge Delay</b>	
Range 0-120 Minutes	<ul style="list-style-type: none"> <li>• Scroll to “PARAMETER MENU” and press “OK”</li> <li>• Scroll to “ALM ACK DELAY”</li> <li>• Press “OK” and change to setting</li> <li>• Select choice and press “OK” and the screen will confirm choice</li> <li>• Press the escape key to revert to home page</li> <li>• It is recommended that the setting is not greater than 1 or 2 minutes</li> </ul>
<b>Tandem Installation</b>	
Assigning the chillers into a single or tandem set installation	<ul style="list-style-type: none"> <li>• Scroll to “PARAMETER MENU” and then to the SYSTEM sub menu</li> <li>• Scroll to “SINGLE/DUAL AUTO” and press “OK”</li> <li>• Change set up to “DUAL AUTO OPER’N” and press “OK”</li> <li>• The screen will confirm your choice</li> <li>• Press the escape key to revert to home page</li> <li>• NB – This only need be done on the master chiller</li> </ul>
Assigning chiller role – Master or Slave	<ul style="list-style-type: none"> <li>• Scroll to “PARAMETER MENU” and then to the SYSTEM sub menu</li> <li>• Scroll to “MASTER/ SLAVE” and assign one chiller the master chiller and one chiller the slave chiller</li> <li>• Screen will show “SET MASTER/ SLAVE” and change to whichever one is which and press “OK”</li> <li>• The screen will confirm your choice</li> <li>• Press the escape key to revert to home page</li> </ul>
Duty Cycle Time	<ul style="list-style-type: none"> <li>• Scroll to “PARAMETER MENU” and then to the SYSTEM sub menu</li> <li>• Scroll to “CYCLE CHANGEOVER” and press “OK”</li> <li>• ‘SET CYCLE PERIOD” will show and the choices are “OFF” where there will be no duty cycling at all but the chillers will still a ct in tandem – ie of one develops a fault it will start the other up. “10 MIN CYCLE TEST” which will duty cycle chiller every ten minutes – this is more for installation testing and will revert to a weekly cycle after to 2 hours and “WEEKLY CYCLE” which will duty cycle the chillers weekly. Note that if chillers are to switch at a set time every week then the timer will need to be set as mentioned above</li> <li>• Press the escape key to revert to home page</li> </ul>
Weekly Timer Reset	<ul style="list-style-type: none"> <li>• Scroll to “CYCLE TIMR RESET” on the home screen</li> <li>• Press “OK” and “ZERO CYCLE TIMR” and “PRESS OK”</li> <li>• “NEW CYCLE STARTED” will show and the clock will reset</li> <li>• At any time during the week the timer can be viewed to see how long to changeover</li> </ul>

# FULL SETTING LIST

Some of the settings are not for this model of chiller and it is recommended that THEY ARE NOT altered without a full understanding of the chillers programming or without checking with Aqua Cooler first. The settings reflect Aqua Cooler recommended setting for the installation ordered. If at a later time another chiller is installed in tandem or the chiller is added. Some of the setting may change.

FRONT PAGE	MAIN MENU	SUB MENU
AQUA COOLER	VIEW INFO	CURRENT IP
		CURRENT TIME
		SOFTWARE VERSION
	VIEW TEMPS	CH W SUPPLY
		CH W RETURN
		AMBIENT TEMP
	VIEW PRESSURES	SUCTION PRESSURE
		DISCHARGE PRESSURE
	VIEW FLOWS	FLOW RATE
	VIEW SPD VALVE %	PUMP SPEED
		COMPR SPEED
		FAN SPEED
		BALL VALVE OPEN
	VIEW HUMID HT LD	HEAT LOAD
	VIEW ON TIMES	COMPR TIME ON
		PUMP TIME ON
		CYCLE TIMR RESET
	KEYPAD STANDBY	KEYPAD STANDBY
	PARAMETER MENU	SYSTEM MENU
		SENSORS MENU
SET-POINTS MENU		
DELAY/HOLD MENU		
SET TIME MENU		
EMAIL/LOGS MENU		

PARAMETER MENU			
SYSTEM MENU			
KEYPAD TIME LOCK	ON	SPRAY COOL	OFF
SPRAY COOL OUTPT	OUTPUT 2	ALARM INDIC	STEADY ALM INDIC
MODBUS LNK LAYER	Ethernet TCP	SNMP DATA	FRACTIONAL
REMOTE RCU SDOWN	OFF	LOW TEMP STOP	YES
HIGH TEMP STOP	NO	RUN PUMP on STOP	NO
CLR WARN on STOP	NO	DISCH PR FAN SP	ON – LOW-FULL SP
VAR SPEED FUNCTN	OFF	No. HE SENSORS	0 HE SENSOR
CLOSE TOLERANCE	Normally OFF (ON for Close Tolerance Units)	STOPon COMP FAIL	YES

CYCLE CHANGEOVER	WEEKLY CYCLE	MASTER/SLAVE	MASTER CHILLER(SLAVE on chiller in redundancy)
SINGL/MULTI/DUAL	SINGLE OPERATION	NETWORK CONTROL	OFF (ON for chillers installed in networked installation)
<b>EMAIL/ LOGS MENU</b>			
EMAIL TX TRIGGER	OFF	DATA LOG PERIOD	60 Seconds
MANAGE DATA LOG	OFF		
<b>SET TIME MENU</b>			
TIME ZONE	Set after install	ADJUST CLOCK/MTH	Set after install
TIME	Set after install	WEEKDAY	Set after install
DAYof MONTH	Set after install	MONTH	Set after install
YEAR	Set after install	SUMMERTME ON/OFF	Set after install
<b>DELAY/HOLD MENU</b>			
ALARM ACK DELAY	10 Seconds	UNLOAD HOLD TIME	15 Seconds
COMPR OFF CYCLE	30 Seconds	COMPR ON CYCLE	30 Seconds
COMPR HOLD TIME	120 Seconds	COMPR START TIME	3 Seconds
PUMP RUN ON TIME	0 Seconds	PUMP DELAY TIME	5 Seconds
HT ALM ACK DELAY	10 Seconds		
<b>SET-POINTS MENU</b>			
SETPT WATER TEMP	7.0 °C	SUPPLY FLOW ALM	0.10 Litre/S
SUPPLY FLOW WARN	0.10 Litre/S	SUPPLY FLOW RATE	6.00 Litre/S (Depends on each application)
LO PR PROTECTION	80 kPa	LP HYST PRESS	200 kPa
LP ALM PRESSURE	80 kPa with R134A 200 kPa with R407C 100 kPa with R410A	LP WARN PRESS	100 kPa with R134A 300 kPa with R407C 200 kPa with R410A
HI PR PROTECTION	2750 kPa	HP HYST PRESS	600 kPa
HP ALM PRESSURE	2300 kPa with R134A 2750 kPa with R407C 3500 kPa with R410A	HP WARN PRESS	2200 kPa with R134A 2600 kPa with R407C 3300 kPa with R410A
FAN MAX SP PRESS	2000 kPa with R134A 2200 kPa with R407C 2200 kPa with R410A	FAN MIN SP PRESS	1200 kPa with R134A 1500 kPa with R407C 1500 kPa with R410A
HYST SPRAY COOL	200 kPa	HP SPRAY COOL	2600 kPa
SETPT AMB O-TEMP	45.0 °C	MAX TEMP LIMIT	25.0 °C
MIN TEMP LIMIT	2.0 °C	RTN W LO TMP ALM	2.0 °C
RTN W HI TMP ALM	30.0 °C	SUP W LO TMP ALM	2.0 °C
SUP W HI TMP ALM	30.0 °C	BALL VLV INTGL	200
BALL VLV GAIN	200	BL VLV MIN OPEN	20 %
PID DAMPING	30	CLOSE TOL TEMP	CLOSE TOL OFF
PULL DN Per Min	0.6 °C	LAST OFF HYST	0.5 °C
TEMP HYSTERESIS	2.0 °C		
<b>SENSORS MENU</b>			
SEC SUPPLY CALIB	See Procedure	FLOW PIPE SIZE	See Procedure
FLOW SENSOR	LITRES/S SENSOR	SUPPLY FLOW CAL	0.60 x Input
DISCH PRESS SIZE	0-30 bar 4-20mA	SUCT PRESS SIZE	0-30 bar 4-20mA
AMBIENT CALIB	See Procedure	SEC RETURN CALIB	See Procedure

## ADVANCED CONTROLLER FUNCTIONS

The units can use Modbus/BACnet via RS485 or TCP/IP using the Ethernet port. The default IP address of our chillers is 10.1.1.130. So you'll need to configure a laptop or computer to be on the same subnet then open a web browser to the web interface at <http://10.1.1.130:8076>

Navigate to 'Network' to change the chiller's network settings. To change between RS485 and TCP/IP go to the controller, Parameter menu – system menu – Modbus link layer – ok – change to your preferred protocol. The detailed steps are presented below.

If you wish to use TCP/IP and need to change the chillers IP address:

1. Connect a laptop directly to the chiller using Ethernet cable
2. Alter your PC network settings so you are on the gateway 10.1.1.1 and subnet 255.255.255.0
3. Open web browser and head to <http://10.1.1.130:8076>
4. Click on "Network", it will ask for a password – username is "techcooler" and password is "techwater"
5. Here you will see all of the chillers IP address settings etc and update as needed. Change the required settings before clicking the "save network confirm" and put the Save Password "aquaipconfig" without quotes into the box.
6. You can find the default chiller BACnetIP (BIP) Device Number (2012), ModBus RTU Slave Addr (1-247) head in the Chiller ID tab. Again, use the save password "aquacustomer" as the password.
7. Then edit the page to the new IP address details for the chiller – again ensuring you enter the password "aquaipconfig" into the save password box.
8. Some other systems settings can be changed remotely. Go the "Control" tab and enter the password "aquachiller" and this will allow the user to send commands to the chiller.

## DOWNLOADING DATA LOG

The chiller is automatically storing data on its operational parameters and performance. In the event that there is a problem with the chiller this data may become useful for diagnosis.

The operational data can be downloaded from the controller by using a USB flash drive there are two types of files on the system – and event log and a time log. The event log takes reading every time there is an event change, compressor on or off for example. The time log saves data every set time period. The default is every 10 minutes but this can be set as low as every 2 minutes. At 10 minutes intervals there is over a week of data saved on the board. The parameters that are logged are the supply, return and ambient temperatures, the suction and discharge pressures and the water flow rate. All changes of state are also logged on the inputs and outputs. Using this data is a good way to check the effective running of the chiller and to help with diagnosis when a service visit is needed.

## To Download via USB:

1. Insert a USB key into the USB key on the rear of the circuit board controller.
2. Go to the PARAMETERS MENU and press OK. Scroll to EMAIL/LOGS MENU and press OK. Then scroll to MANAGE LOG DATA LOG and press OK.
3. There a number of options in the sub menu (SET LOG START) – the most useful are TIME LOG TO USB and EVENT LOG TO USB. Press OK and the data will start to upload – the screen will confirm when the process is complete.
4. The process has to be done twice – once for each file.
5. Putting the USB into a computer will show the folder labelled “AQUA” and inside this will be a excel data file. The excel file will have labels for all the data that has been logged – the newest data will be at the top.

NOTE: the shorter the time between readings the less history the system can record. 10 mins should give approximately 3 weeks of data logging – 10 second intervals will only give 24 hours of data logging and the logging drops the old files off the end so if the unit has a problem and it takes more than one day to get to site then the relevant data will be gone.

The other way to download the data is via webpage – to “advanced” tab on the webpage and then to the download tab – the drop-down list will then give you the option of downloading the files. The controller will ask you to save the file somewhere.

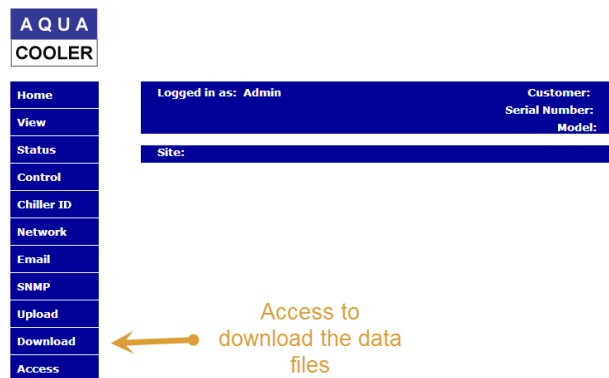

## Calibration of Sensors-Aqua Cooler Controller

The temperature sensors will be calibrated before dispatch but in the even one needs to be replaced then it is a good idea to recalibrate the sensors as they effect the operation of the chiller.

1. Scroll through the controller to parameters menu
2. Scroll down to the Sensor Menu sub- menu
3. Scroll through to the ambient, supply or return calibration
4. Place the sensor and a calibrated thermometer together and allow the temperature to settle
5. Press OK and the value will flash. Use the up and down scroll buttons to calibrate the sensor to the thermostat and press OK again
6. Exit the program

## Updating Software

The chiller is dispatched with the latest firmware always installed however should a software upgrade be required then it can be done simply by following the instruction below.

- Firmware and USB

The firmware will be emailed, and it will have a HEX extension at the end of the file. For example, U264\_32\_EB4\_XXX.hex. Upload this file onto the USB stick making sure it is the only HEX file in the root directory of the USB stick.

- Set PCB to updating mode

Hold “Down” and then press “Reset” button. PCB screen will show [Aqua Cooler Boot: F/W: (Current Firmware) ] and then change to [Aqua Cooler Boot: Await USB File]

- Insert USB

Insert the stick into the USB port of Aqua Cooler controller – controller will look for the file automatically and start the upload. The screen will confirm upload in progress and confirm when it is complete. It should take about 30 seconds. None of the setting in the controller will change except the feature that the upgrade is improving, adding, or fixing.

- BMS system and internet connection

For units that are connected to the internet or to a BMS system the BIN file will need to be updated as well to the corresponding issue number. Using a laptop connect to the Aqua Cooler controller via the Ethernet card in the rear of the controller.

Open a browser with <http://10.1.1.130:8076/mpfsupload> OR if the controller has already been configured to a unique IP address then use this address. Use the BROWSE key to retrieve the BIN file saved to your computer or USB key. Once this is uploaded the page will show a tab with “Site Main Page” on it. Click on this and it will direct you to the main monitoring page for the chiller. The instructions are above for moving further into the control and monitoring of the chiller.

The IP address of the unit can be found by scrolling to the INFO menu on the home screen of the controller.

- Set time, date, and year

In the parameter menu there is time, date and year menu lines that can be set (see the service section for instructions) in order that the data log periods and the email alarms are time relevant.

There are other parameters in the programming menu: Some are used in some of the other options. The setting should not be altered altering the parameters not relevant to the operation of your chiller may affect its performance and required an out of warranty service call.



# Controller Input and Output Schematic

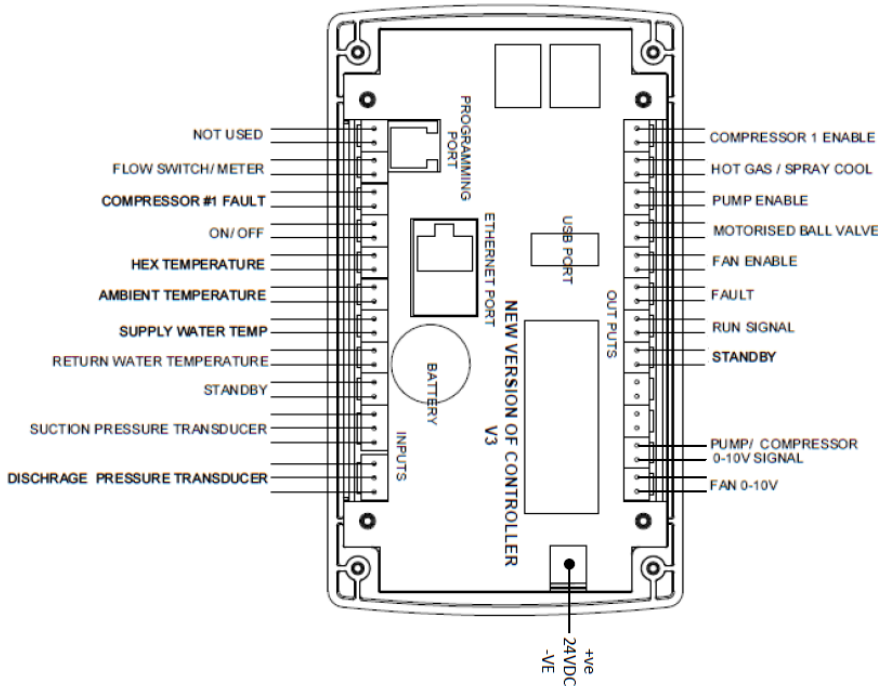

Connector	Type	Control
Outputs – OUT1 to OUT12 across the top of the board	24VDC  0-10 Volt out put 0-10 Volt out put	1 Compressors 2 Hot Gas/ Spray Cool 3 Pump 4 Ball Valve 5 Fan Bank 6 Master Fault 7 Master Run 8 Standby/ Tandem link enable/ Status 11 Variable Speed Compressor Control 12 Fan speed control
Inputs – IN1 to IN10 across the bottom of the board IN1 (NOT USED) IN1 IN2 IN3 IN4 IN5 IN6 IN7 IN8 IN9 IN10	Not Used 0-24VDC Input 0-10V NC Input 0-10V NC Input 0-10V/ NTC thermistor 0-10V/ NTC thermistor 0-10V/ NTC thermistor 0-10V/ NTC thermistor 0-10V NC input 0-10V Input 0-10V input	Not Used Supply Pump Flow Meter Compressor 1 fault input ON/OFF Switch Plate pack safety sensor Ambient temperature sensor Chilled water supply temperature sensor Chilled water return temperature sensor Standby/ Tandem link Suction pressure Discharge pressure
Please note: There are two IN1s at the bottom of the board. The first IN1 at the edge is not used.		

# TROUBLESHOOTING

In the event the chiller develops a fault then the fault is displayed on the screen readout on the control board. The faults displayed are comprehensive but not fully descriptive.

Symptom	Possible Causes	Solutions
Low Flow Alarm	Faulty Pump	Replace Pump ensuring new pump has been leak tested, phase wiring is around the right way
	Blockage on water circuit of chiller installation	Check water flow is coming back through to chiller. Water line isn't isolated down the line. Water strainer is clean and clear (if installed in water pipe work. If plate pack evaporator is used check there is flow through the heat exchanger. If blocked replace heat exchanger. Faulty electrical contractors – check operation and replace if necessary
	Work Around	Set water flow alarm and protection to 0 while you test unit. (if unit has plate pack isolate compressors while testing)
	Faulty Flow meter	Check flow meter spindle if free and not stuck, flow meter has voltage (24VDC) wiring connections are not loose. By-pass is not fully open.
Compressor Fault	High head pressure – HP alarm tripping	Check head pressures when the unit is running. Possible causes blocked condenser – check for dust or debris build up and clean. Refer to “Poor Heat Dissipation” section.
		Dead or dying fan – check amp draw of fans or air flow. Replace if needed
		Too high a heat load for the rating of the unit. Check install and site specifications
		Bad installation or too high ambient – check that there is no other equipment in the vicinity that may be throwing heat onto the unit or that the unit has not been installed improperly
		Faulty HP transducer or HP switch - replace
	Low pressure – LP alarm tripping	Flow rate from pump may be too low
		TX valve may have seized
		Unit may have developed a refrigeration leak and lost gas charge – check pressures or run leak detector over the unit.
		Outlet water temperature and evaporator temperature too low. Check whether there is a lack of water in the water tank and whether the circulating pump is running well. If those are normal, reset the low pressure switch or restart the unit. If the evaporator is frozen, input warm water to melt the ice. Do not attempt to break the ice off with force.
	Work Around	Motor protection module in compressor tripped Motor running too hot – return water may be too high in-rush of heat load. Compressor drawing too much current
Multi compressors	For multiple compressor units, Second compressor should still be running and carrying much of the heat load. Once the faulty compressor is fixed then the programming will have to be updated as the program will have defaulted to another setting to keep the unit running. On the screen go to “PARAMETERS MENU” and press “OK” Scroll to SWITCH ON FOR NEXT C” – “TIMER” should be showing underneath this. Press “OK” and scroll to “FIXED HEAT LOAD” and press “OK”. The screen should confirm your choice	
No Power	Main breaker off	Check main breaker is on, If on and no power have a qualified person test power to the unit.
PCB blank	No mains power	Check main breaker is on, If on and no power have a qualified person test power to the unit
	No control voltage	Check PCB has 24vdc to controller. If power is present replace PCB

<b>C1 FLT Fault</b>	Safety switch open	Check operation of safety switches (circuit that connects to input 2) Check Hp, LP, water level switches are made. Fan/pump and compressor overloads are made.
	Work Around	Bridge out components one after the other and test to see when unit doesn't trip.
<b>HP Fault</b>	Faulty Fans	Check operation of condenser fans. Replace if faulty.
	Condenser coil dirty	Check condition of condenser is clean and air moves through freely over coil.
	Ambient Temperature to High	Ambient temp to high. Condensing temp to be brought down. (Spray coils with water)
	Faulty transducer	Check operation of transducer/ reading correctly
<b>LP Fault</b>	Low refrigerant charge	Check refrigerant system operation, check super heat and sub cooling are with in normal operating ranges
	Faulty Tx Valve	Check operation of Tx valve (opening and closing as required)
	Low water flow	Check water flow through plate pack heat exchanger is sufficient
	Water fouling	Check buffer tank and coil water is clean and coil not coated in mud/debris
	Faulty transducer	Check operation of transducer/reading correctly
<b>High Return Water Temp</b>	Faulty Probe	Check probe operation/Re-calibrate sensor, replace probe
	Low refrigerant charge	Check refrigerant system operation, check super heat and sub cooling are with in normal operating ranges
<b>High Supply Water Temp</b>	Faulty probe	Check operation of transducer/reading correctly
	Low refrigerant charge	Check refrigerant system operation, check super heat and sub cooling are with in normal operating ranges
<b>High Ambient Temp</b>	Faulty probe	Check operation of transducer/reading correctly
	Air Re-circulation	Check condenser air is not recirculating back over the condenser coil
<b>Low Return Water Temp</b>	Faulty probe	Check operation of transducer/reading correctly
	Low Water Flow	Check water flow through plate pack heat exchanger is sufficient. Check pump operation. Replace pump if at fault
	Low refrigerant charge	Check refrigerant system operation, check super heat and sub cooling are with in normal operating ranges

## Poor Heat Dissipation

While the condenser heat dissipation is poor, the compressor will be inefficient and the operating current will be increased. When the chiller reaches the high pressure value (set depending on the chiller type and refrigerant used), the high pressure switch will trip an alarm and the unit will stop working. This can be caused by poor heat dissipation. For air-cooled chillers, confirm that the condenser is not dirty or choked and have a good airflow. Once the above conditions are checked to be in normal condition, clear the alarm. If the high-pressure alarm is frequently occurring, clean the condenser as soon as possible.

## Low Refrigerant

If the pressure at the gauge is pressure low, it may indicate a shortage of refrigerant. Any leaks should be filled, the dryer filter should be changed, and it should be drawing a vacuum again. Refill the refrigerant after the above has been performed.

If the leaking part is within water, stop the chiller immediately and discharge the water in the water tank quickly. The compressor can be damaged badly if it sucks in water.

## Low and High Pressure Difference

While the compressor is running, if the difference between high pressure and low pressure is small, it may indicate the piston inside the compressor is damaged. If this is detected, the unit should be stopped immediately. It is normal for the pressures to be similar if the compressor is not running.

## Compressor Not Starting

If the fault indicator and the protection switch are normal, but the compressor will not start, please check the following:

1. The set temperature is too high or the temperature sensor is damaged
2. The PCB button is damaged
3. The anti-freezing switch is damaged
4. The pressure switch is damaged
5. The overload protector of the compressor is damaged
6. The electromagnetic relay is damaged or the overload protector is damaged
7. The water level is too low
8. The refrigerating water protecting switch is damaged

# MAINTENANCE

## Warning

- Always isolate the power from the chiller prior to working on the unit.
- Always ensure that personnel have read and understood the SAFETY section of this manual prior to working on the chiller.
- When the mains controller is de-energised the power contactors are live, even if the components are not operating. All maintenance must be carried out by qualified refrigeration mechanics.

These units have been designed for the minimum of maintenance. However to ensure optimum performance qualified personnel should carry out regular maintenance. A comprehensive preventative maintenance program is available through Aqua Cooler carried out by qualified refrigeration mechanics. If there is any fault or concern during daily operation, please contact Aqua Cooler to arrange a service call.

## Recommended Preventative Maintenance Program

A comprehensive preventative maintenance section is included in the back of this manual

Operation	Frequency
Refrigerant Charge	6 Monthly
Electrical connections are tight	6 Monthly
Compressor amp draw	12 Monthly
Pump amp draw	12 Monthly
Condenser strainer cleaned	6 Monthly

## WARRANTY

Any claim under this warranty must be made within the discussed time period of the date of purchase of the product. To make a claim under the warranty, return the product (with proof of purchase) to the supplier where you purchased the product or contact Aqua Cooler regarding warranty conditions.

Aqua Cooler will pay your reasonable, direct expenses of claiming under this warranty. You may submit details and proof of your expense claim to Aqua Cooler Pty Ltd for consideration. This warranty is given by Aqua Cooler Pty Ltd, U14, 2-12 Knobel Court Shailer Park 4128 QLD.

This warranty is provided in addition to other rights and remedies you have under law: Our goods come with guarantees which cannot be excluded under Australian Consumer Law. You are entitled to replacement or refund for a major failure and to compensation for other reasonably foreseeable loss or damage. You are also entitled to have the goods repaired or replaced if the goods fail to be of acceptable quality and the failure does not amount to a major failure.

A comprehensive commissioning procedure is attached in the end of the manual. This must be carried out in accordance with the procedure and returned to Aqua Cooler at [support@aquacooler.com.au](mailto:support@aquacooler.com.au). Aqua Cooler offers a commissioning program and can arrange this for you. Failing to follow the commissioning procedure may void this warranty.

## GENERAL APPLICATION

The chiller is designed to refrigerate and circulate water to a heat developing process to aid in keeping that process cool. They are supplied with an immersed coiled copper evaporator, or plate heat exchanger, or shell&tube evaporator (model dependant) an air cooled condenser and a scroll compressor to circulate the refrigerant gas. Water is circulated out of the unit via a pump. The chiller is design to be installed outdoors and refrigerate water for a heat developing process – not for drinking or food preparation purposes. Any other use of this water chiller is a not as it is intended.

# Installation Sketch Map of Air Cooled Chiller

## Customers Equipment/Process

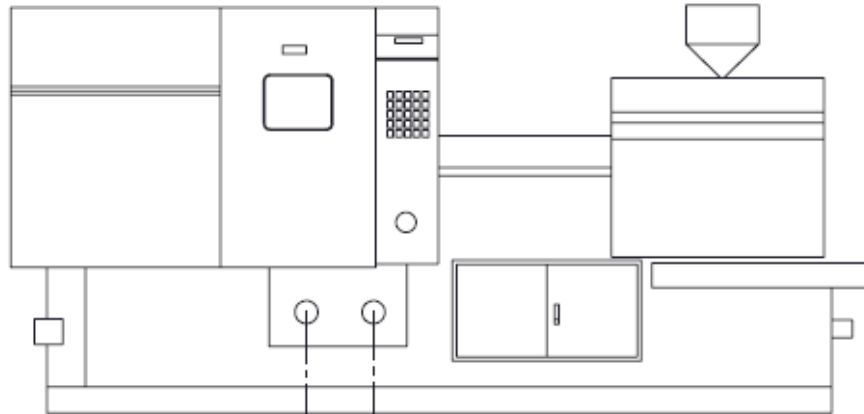

----- Chilled Water

## Air-cooled Chiller

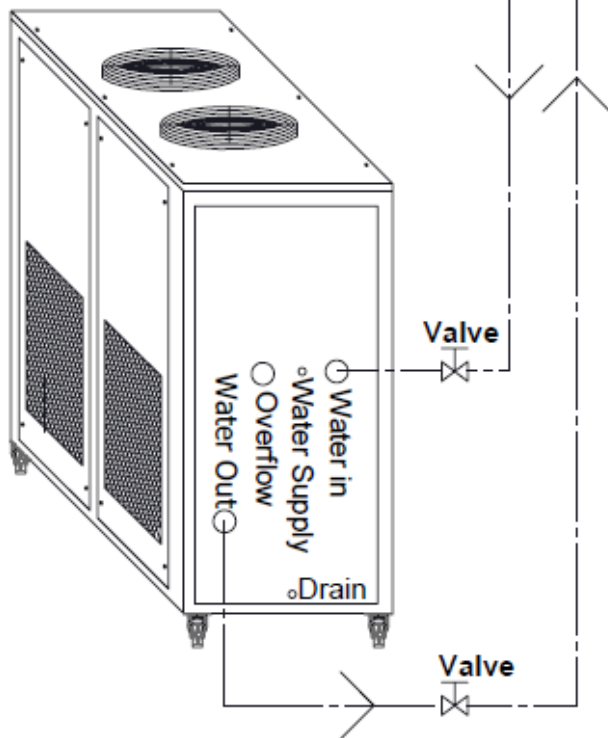

# Installation Sketch Map of Water Cooled Chiller

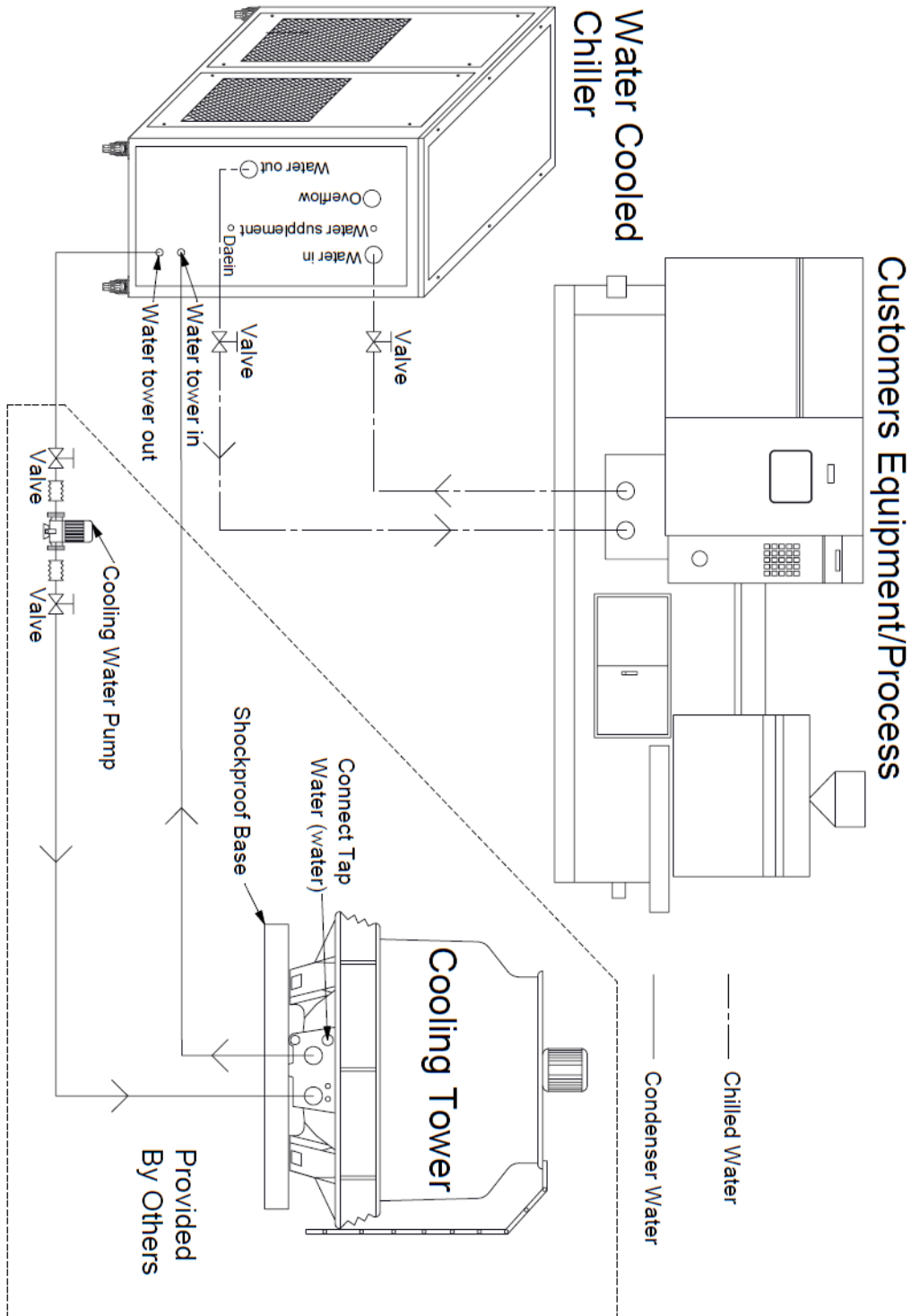

# Internal Structure Sketch Map of Air Cooled Chiller

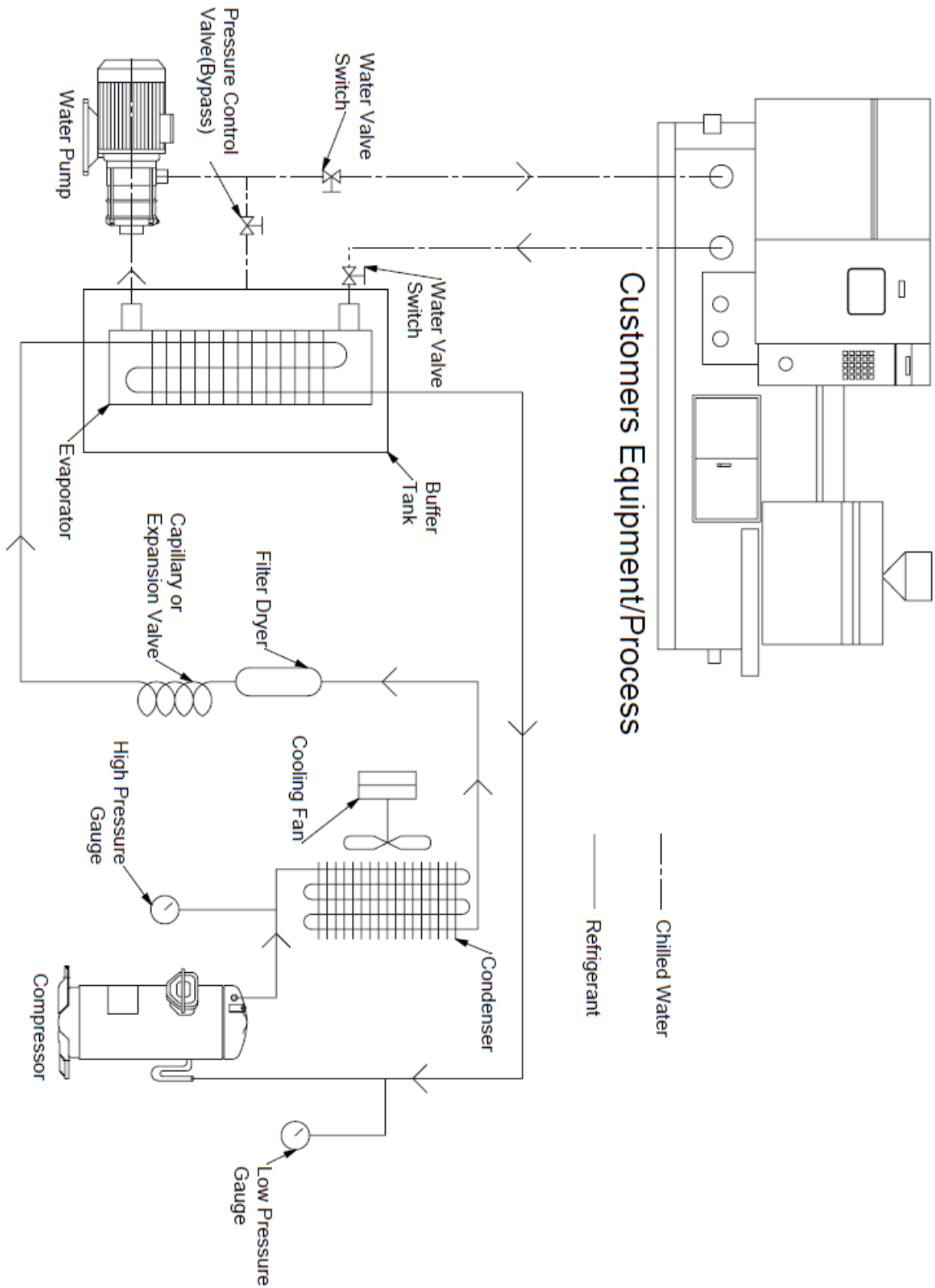



# Internal Structure Sketch Map of Water Cooled Chiller

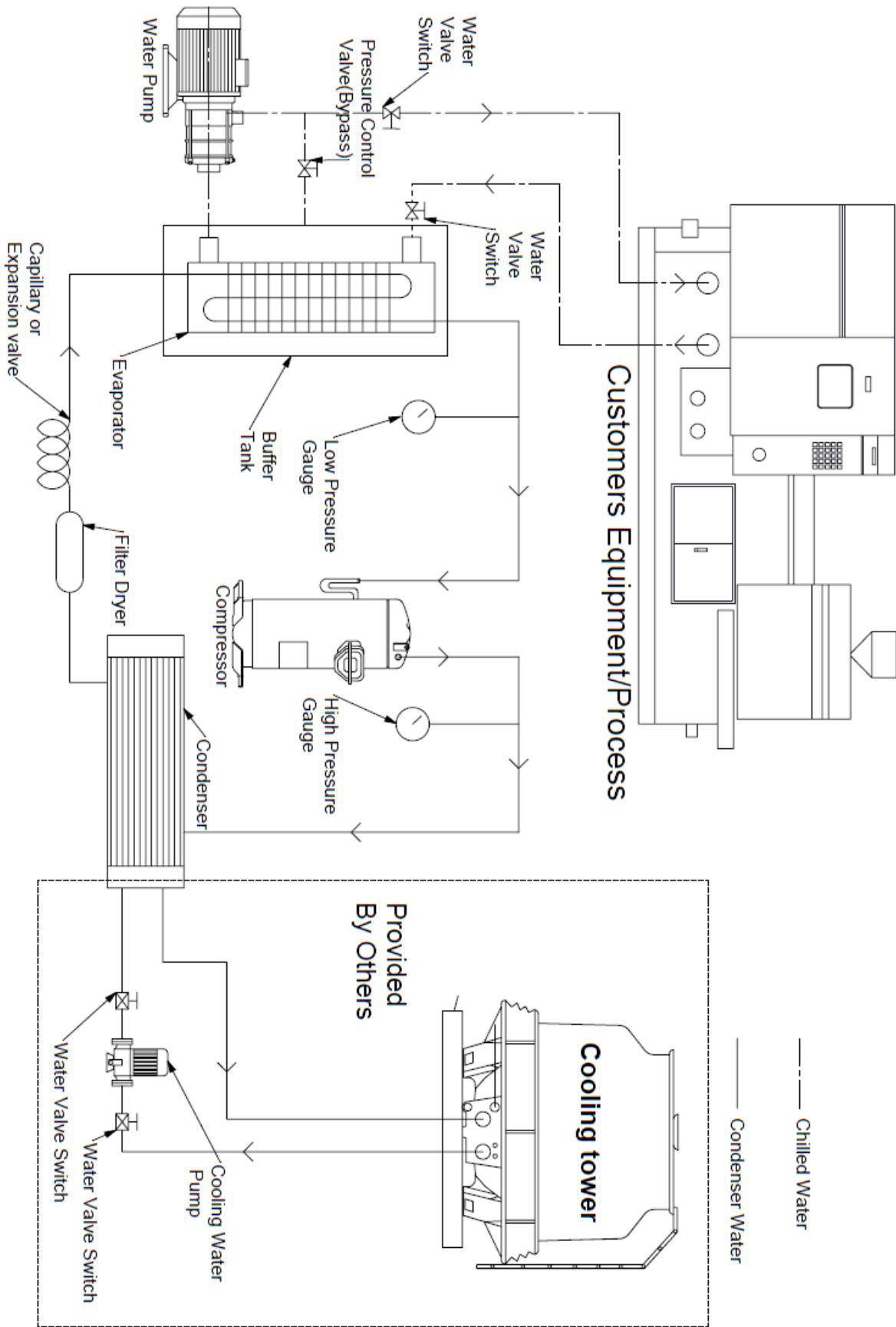

# COMMISSIONING SHEET

It is important that the chiller is commissioned in accordance with the guidelines in the end of the manual in order to ensure proper and trouble free operation. Outlined below is a check list showing all the considerations that must be taken for the proper installation and operation of chillers. Please print out the table and check through it one by one. Please take a photo of the completed table and send it back to us.

Customer and On Site Requirement			
Required Capacity:	kW	Rated Ambient Temp:	°C
Rated Supply Temp:	°C	Rated Flow Rate:	L/s
Customer:			
Address:			
Machine Information			
Chiller model:		Chiller Serial Number:	
Program Version:		Power – Voltage	V
Connect Pressure Gauges to Suction and Discharge Lines			
Suction Pressure (LP):	kPa	Discharge Pressure (HP):	kPa
Refrigerant Leak Test:			

Pump (YES/NO)			
Pump Running Check:		Pump Rotation check:	
Water Leaks Check:		In Line Filtration:	
Water Pressure:	kPa	Performances fall on the respective pump curve:	
Water bypass Check:			
Fans (YES/NO)			
Fan Rotation check:		Condenser Fans Current	Amp

Fan speed control:			
<b>Chiller Water Circuit Requirements (YES/NO)</b>			
Pipe Size:	inch	Pipe Insulation:	
Length:	m	Height Difference:	m
Balancing Valve:		Isolation Valves:	
Water Treatment:		Make Up Water:	
Treatment Used and Others Notes:			

<b>Operation Testing: (YES/NO)</b>			
Ambient Temp:	°C	Water Set Point:	°C
Temp Controller Reading Check:		Fault Buzzer/Light Works:	
Sight Glass Clear:		Unit Handles Heat Load:	
On/Off Button Works:		Check Oil level on the compressor sight glass.	
<b>Operation Testing – Current:</b>			
Chiller Running Current:	Amp	Pump 1 Current	Amp
Compressor 1 Current:	Amp	Pump 2 Current (if fitted)	Amp
Compressor 2 Current (if fitted)	Amp	Redundant pump (if fitted)	Amp
Pump 1 Flow Rate:	L/s	Condenser Fans Current	Amp
Pump 2 Flow Rate: (if fitted)	L/s		

<b>Installation and Build Check (YES/NO)</b>			
Any damage from transport		Adequate clearance around and above	
Electrical isolation switch		Inside chiller clean	
Panels are clean		All settings to factory default	
Pipes to the process		All marking in place	
Panels secure		Electrical wiring is tight	
Electrical box secure		Electrical box tidy	
Water drained from unit		Correct manual sent with chiller	
Water pipe with insulation		Earth connected	
Ensure power connection between chiller and condenser is secured. (Remote condenser)		Wire routing clear of hot spots, sharp edges and screws	

<b>Commissioning by:</b>			
Inspected by:		Company:	
Contact number:			
<b>Installation site:</b>			
Business name of site:		Site contact name:	
Site contact phone no.:		Sit contact position	
Note regarding to refrigeration cycle:		Note regarding to water cycle and application:	
<b>Completion:</b>			
<p>Aqua Cooler uses the information from this data sheet to confirm that the chiller is installed and operating correctly. Should any problems or issues be raised as a result of this preventative maintenance procedure then Aqua Cooler will take steps to address them with the customer, ensuring that the chiller operates reliably and without compromise to the long service life we expect of our products. We appreciate any feedback given as all data is used to influence our continual product development program.</p>			

Date:		Agent print name:	
		Agent signature:	
Date:		Customer representative print name:	
		Customer representative signature:	
<b>Filing – Aqua Cooler:</b>			
Date:		Print name:	
		Signature:	

# PREVENTATIVE MAINTENANCE PROCEDURE

## Customer requirements pre-site visit:

- Ensure chiller is accessible and work area is safe.
- Provide details on any site access restrictions including hot works permits, induction course requirements etc.

## Pre-check procedure:

- Discuss with the customer any concerns they may have regarding the chiller's operation.
- Check the clearances around the chiller, ensuring they are adequate for service access and for free and unobstructed access for primary air to the chiller.
- Check for any obstructions above the condenser fans that may hamper free air flow or may lead to air re-circulation through the condenser. Clean condenser fins.
- Check that an isolation switch has been provided close to the chiller in a clearly visible location and that power has been supplied to the chiller.
- Check that there is adequate provision of drainage should the tank need to be emptied at any point.

## Check chiller operation:

### Refrigeration circuit

- Visual inspection of chiller's exterior while running, noting any damage, noise, vibration, or other obvious problems.
- Remove panel work and complete inspection of interior of chiller, noting any damage, noise, vibration, or other obvious problems.
- Clean condenser coil and evaporator as required.
- Connect refrigerant gauges to the chiller and confirm that the refrigerant charge has not been lost.
- Check the refrigerant sight glass for evidence of moisture or excessive bubbling.
- Monitor high- and low-pressure levels and superheat.
- Check oil levels in compressor.
- Check for any indication of a temperature difference across the drier, inspecting drier for blockages.
- Using leak detector search for evidence of gas leaks.

## Electrical system

- Isolate the chiller and check that all terminals within the electrical enclosure are tight.
- Tighten all other electrical connections. Re-apply power.
- Measure line voltages on each phase entering the chiller.
- Measure the current draw on the fans.
- Measure the current draw on all other motors and record readings.

## Water circuit

- List down any relevant notes regarding the chilled water circuit, noting any issues that could pose problems including susceptibility to condensation or poor workmanship.
- Check water/fluid quality and level. Drain and clean the tank as required.
- Check and clean filters and strainers as required.
- If running, check the supply pressure and flow rate.
- Check whether the make-up water is directly connected to mains pressure and operating correctly.
- Note whether any water treatment is being used, or if provision has been made for water treatment
- Check whether the customer or the customer's agent has proposed to use water treatment.
- Check the pump current draw and record.

## Operational check

- Confirm water temperature is set to the desired set point and chiller is operating as per the customer's requirements.
- Note the ambient temperature.
- As the water temperature approaches the set point, check the current draw on each compressor phase, note discharge and suction pressures then measure the Tx bulb temperature and the liquid line temperature between the drier and the Tx valve.

## On completion

- Re-fit and clean all panels.
- Ensure no rubbish is left around the outside of the chiller.
- Discuss results of preventative maintenance with the customer, or the customer's agent. Detail basic operation of the chiller to the customer, or the customer's agent. Detail that any problems with the chiller should be referred directly to Aqua Cooler by calling 1800 278 226 per the service sticker on the chiller and quote the serial number.

# NOTES